



SERVICE MANUAL

** Updated technical documentation is attached to the end of this manual.*



MODEL D330 MIXER

D330

ML-38944

- NOTICE -

This Manual is prepared for the use of trained Hobart Service Technicians and should not be used by those not properly qualified.

This manual is not intended to be all encompassing. If you have not attended a Hobart Service School for this product, you should read, in its entirety, the repair procedure you wish to perform to determine if you have the necessary tools, instruments and skills required to perform the procedure. Procedures for which you do not have the necessary tools, instruments and skills should be performed by a trained Hobart Service Technician.

The reproduction, transfer, sale or other use of this Manual, without the express written consent of Hobart, is prohibited.

This manual has been provided to you by ITW Food Equipment Group LLC ("ITW FEG") without charge and remains the property of ITW FEG, and by accepting this manual you agree that you will return it to ITW FEG promptly upon its request for such return at any time in the future.

TABLE OF CONTENTS

GENERAL	5
INTRODUCTION	5
SPECIFICATIONS	5
MOTOR	5
OPERATING VOLTAGE	5
WEIGHT AND DIMENSIONS	5
LUBRICATION	5
TOOLS	5
OPERATION AND CARE	5
REMOVAL AND REPLACEMENT OF PARTS	6
COVERS	6
PLANETARY/INTERNAL GEAR	6
REMOVAL	6
DISASSEMBLY	7
TRANSMISSION	8
TRANSMISSION DISASSEMBLY	8
PLANETARY SHAFT DISASSEMBLY	10
PLANETARY SHAFT ASSEMBLY	10
TRANSMISSION SHAFT DISASSEMBLY	10
TRANSMISSION ASSEMBLY	11
SHIFTER UNIT	11
REMOVAL AND DISASSEMBLY OF SPEED SELECTOR	11
ASSEMBLY AND INSTALLATION OF SPEED SELECTOR	12
REMOVAL AND DISASSEMBLY OF SHIFTER YOKE	12
ATTACHMENT HUB	13
COUNTERBALANCE SPRING	13
BOWL LIFT UNIT	14
BOWL LIFT HANDLE/BOWL LIFT ARM	14
BOWL LIFT ROD	14
BOWL SUPPORT	15
REMOVAL	15
INSTALLATION	15
MOTOR	16
REMOVAL	16
DISASSEMBLY	16
INSTALLATION	17
BASE AND PEDESTAL	18
REPLACING THE BASE	18
REPLACING THE PEDESTAL	18
SERVICE PROCEDURES AND ADJUSTMENTS	19
BOWL ADJUSTMENTS	19
BOWL CLAMP ADJUSTMENT	19
BOWL LOCK ADJUSTMENT	19
BOWL TO BEATER CLEARANCE	19
BOWL SUPPORT	20
WORM GEAR SHAFT	20
PLANETARY SHAFT SHIMS	21
ATTACHMENT HUB BEVEL GEAR SPACING	21
SPEED SELECTOR SWITCH	21
TESTING MOTOR CURRENT	22
POWER FLOW DIAGRAMS	22
ELECTRICAL OPERATION	24
COMPONENT FUNCTION CHART	24
COMPONENT LAYOUT	24

ELECTRICAL DIAGRAMS 25

TROUBLESHOOTING 26

 TROUBLESHOOTING 26

GENERAL

INTRODUCTION

The Model D-330 is a heavy duty (30 quart) mixer with positive drive three speed transmission and the exclusive planetary mixing action. Centralized controls facilitate ease of operation. Fifteen minute timer control is standard equipment. The D-330 is equipped with the standard No. 12 taper attachment hub.

SPECIFICATIONS

MOTOR

1-1/4 H.P. Hobart-built, permanently lubricated ball bearings with external ventilating fan. Single-phase is capacitor start, capacitor run type. Three phase is squirrel cage, induction run type.

OPERATING VOLTAGE

*120/60/1

208/60/1

*240/60/1

208/60/3

*240/60/3

*480/60/3

* Dual voltage motor

OPERATING SPEEDS

Speed	Agitator RPM	Attachment RPM
1st	96	54
2nd	176	100
3rd	321	183

WEIGHT AND DIMENSIONS

Height - 50-27/32"

Width - 22-1/64"

Depth - 30-1/4"

Net Weight - 472 lbs.

LUBRICATION

A list of acceptable LUBRICANTS, as well as the lubricants themselves, are available from your local Hobart Service Office.

TOOLS

- Standard set of hand tools.
- VOM with AC current tester (any quality VOM with a sensitivity of 20,000 ohms per volt can be used).
- Bearing puller.
- Seal installation tool No. 55460-3.

OPERATION AND CARE

Detailed operation and care instructions are included in the "Instructions" manual included with each new mixer.

REMOVAL AND REPLACEMENT OF PARTS

COVERS

⚠ WARNING

DISCONNECT THE ELECTRICAL POWER TO THE MACHINE AT THE MAIN CIRCUIT BOX. PLACE A TAG ON THE CIRCUIT BOX INDICATING THE CIRCUIT IS BEING SERVICED.

Removal

1. Top cover.

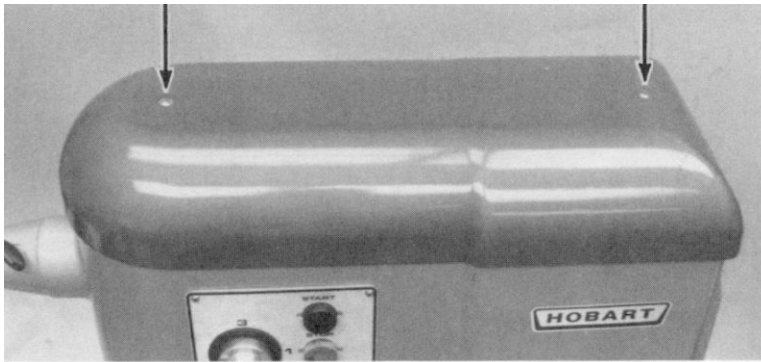

Fig. 1

2. Motor access cover.

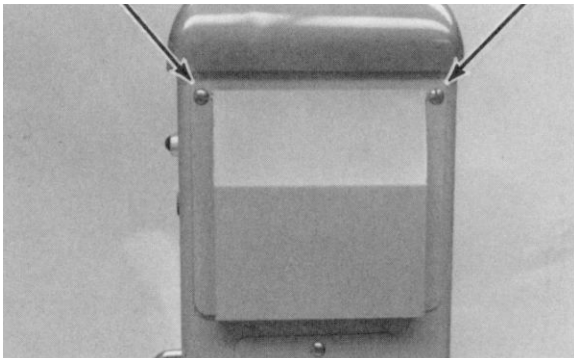

Fig. 2

3. Bowl lift access cover.

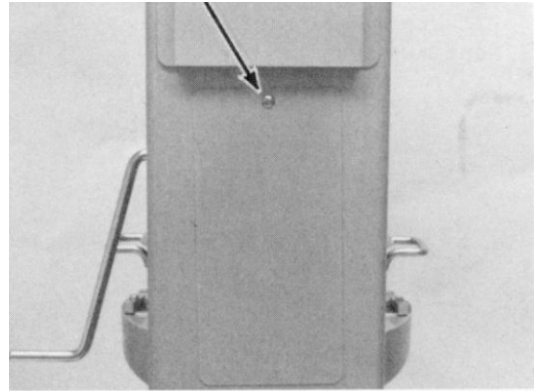

Fig. 3

PLANETARY/INTERNAL GEAR

REMOVAL

⚠ WARNING

DISCONNECT THE ELECTRICAL POWER TO THE MACHINE AT THE MAIN CIRCUIT BOX. PLACE A TAG ON THE CIRCUIT BOX INDICATING THE CIRCUIT IS BEING SERVICED.

See TSB 787B D330/D340/D340PFS - AGITATOR SHAFT ASSEMBLY/PLANETARY ASSEMBLY/ EXPANSION PLUG IMPROVEMENTS

1. Remove drip cup (2 thumb screws).

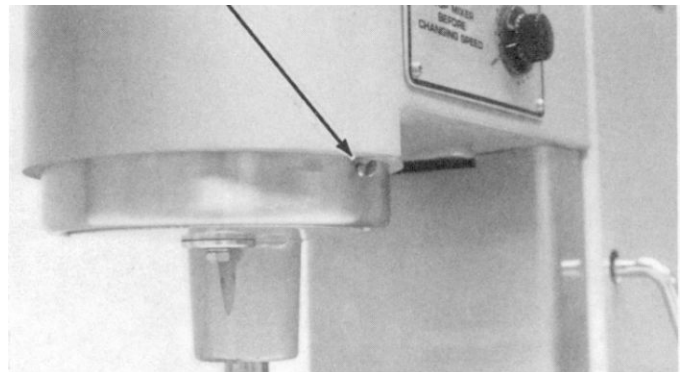

Fig. 4

2. To keep the planetary shaft from turning, put a flat "B" beater on and hold it while loosening the retaining screw.

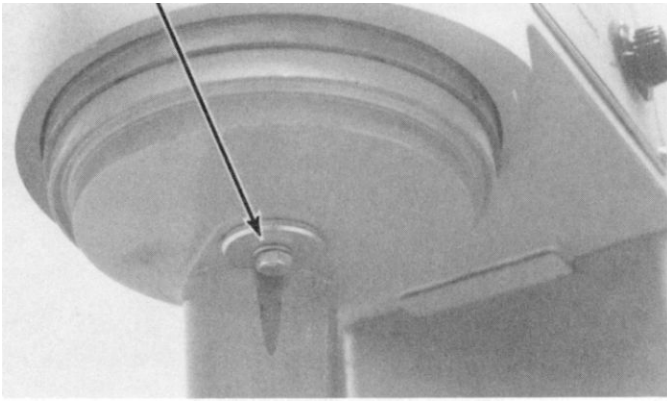

Fig. 5

3. Remove retaining screw, lockwasher and planetary washer while supporting the assembly.
4. Slide the planetary from the shaft and remove key.

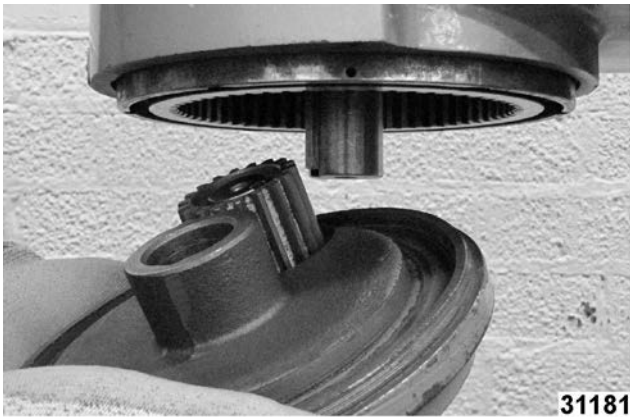

Fig. 6

5. To remove the internal gear, remove six screws that hold it to the gear case.

NOTE: When installing internal gear, be sure holes for drip cup screws are located to the sides of the mixer.

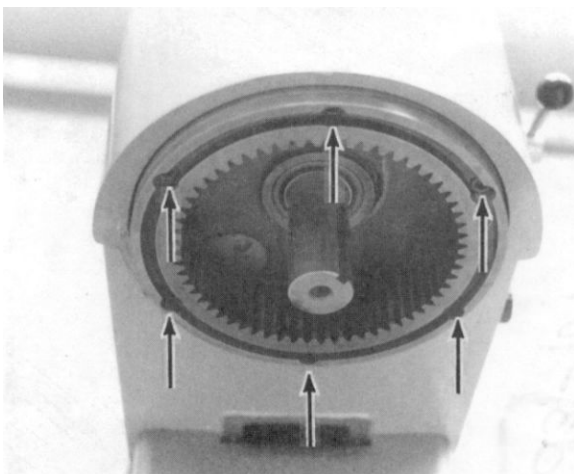

Fig. 7

6. Reassemble in reverse order of removal.

DISASSEMBLY

1. Remove retaining ring, pinion and key.



Fig. 8

2. The agitator shaft can be pressed out of the planetary from the top side.

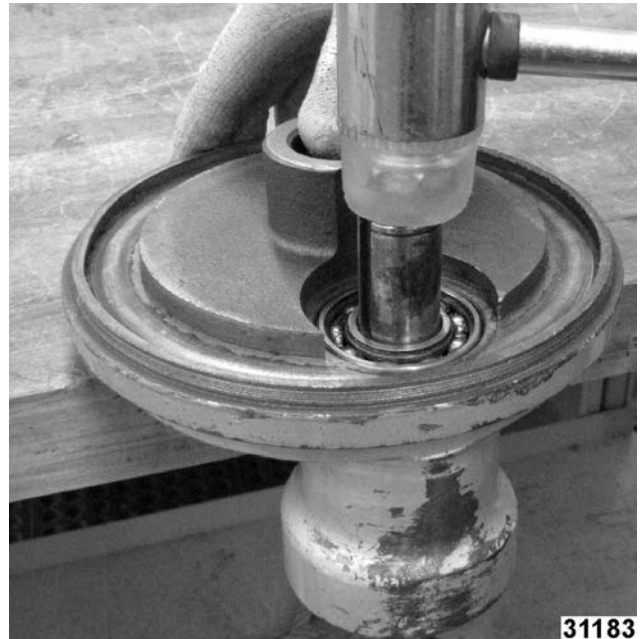

Fig. 9

3. Remove upper bearing with a driving sleeve.
4. Remove the lower bearing and seal from the top of the shaft.

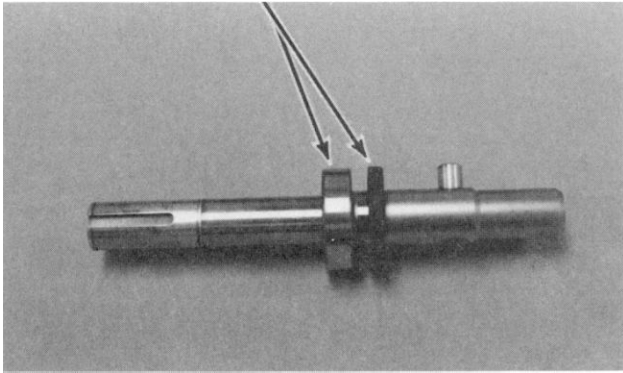

Fig. 10

5. Reassemble in reverse order of disassembly.

TRANSMISSION

TRANSMISSION DISASSEMBLY

⚠ WARNING

DISCONNECT THE ELECTRICAL POWER TO THE MACHINE AT THE MAIN CIRCUIT BOX. PLACE A TAG ON THE CIRCUIT BOX INDICATING THE CIRCUIT IS BEING SERVICED.

1. Remove bowl, agitator, top cover and motor access cover.
2. Remove planetary. See [PLANETARY/ INTERNAL GEAR](#).
3. Drain transmission by removing drain plug.

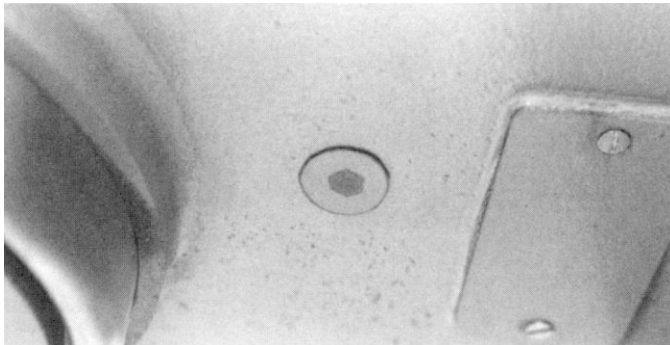

Fig. 11

4. Remove the worm shaft and planetary shaft bearing retainer covers.

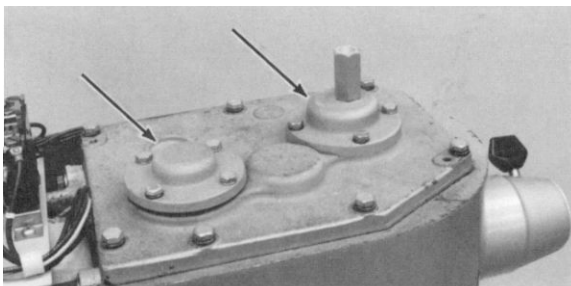

Fig. 12

5. Bend down the tabs on the worm shaft and planetary shaft lockwashers and remove the locknuts.



Fig. 13

6. Remove seven bolts that hold down the transmission cover and carefully pry off the cover. Check for spacers stuck to bottom of cover.

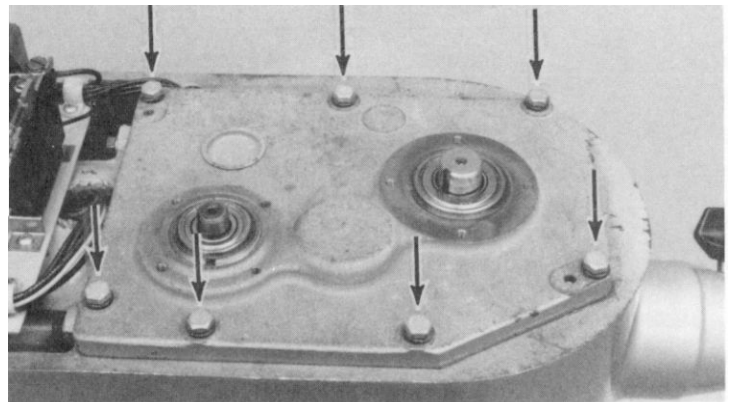

Fig. 14

7. Remove the speed selector handle and switch cover plate.



Fig. 15

8. Remove the speed selector cam.

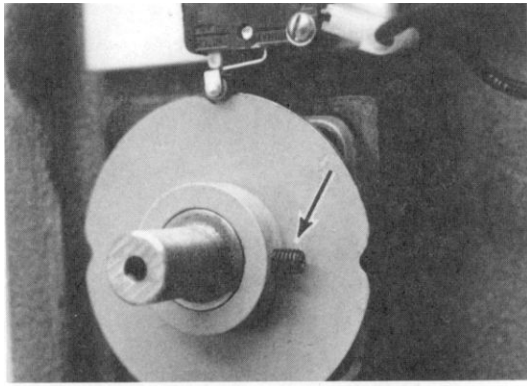

Fig. 16

9. Remove the speed selector assembly.

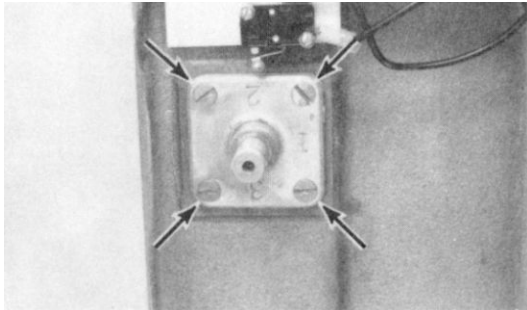

Fig. 17

10. Remove shifter shaft and shifter yoke.

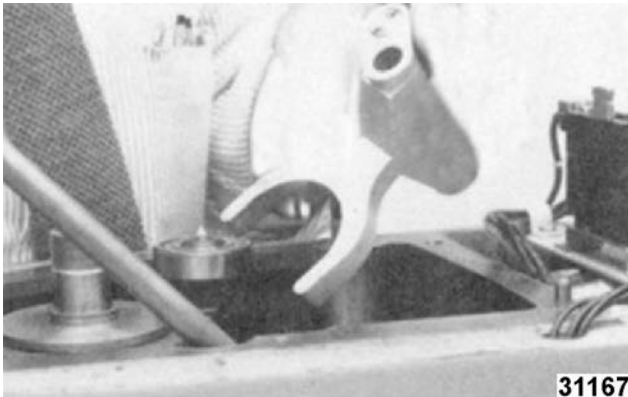

Fig. 18

11. Remove the following parts from the planetary shaft in the order listed.
- A. Upper planetary shaft spacer. There should be 1 to 3 thin (.010") shims above the spacer.

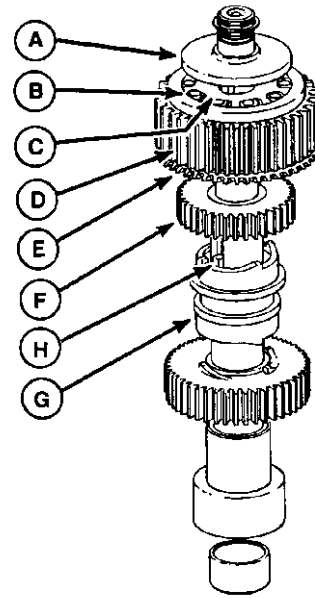

Fig. 19

- B. Ten clutch rollers and roller springs.
 - C. Mark top for identification and remove drive sleeve.
 - D. Roller clutch gear.
 - E. Bevel gear and key.
 - F. Upper clutch gear and bushing.
 - G. Clutch sleeve.
 - H. Keys (2).
12. Remove planetary shaft and transmission shaft together.

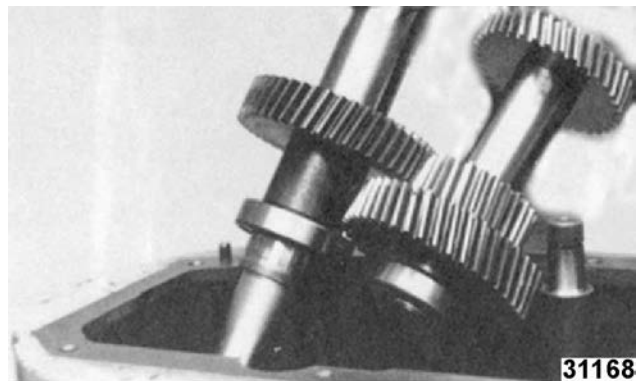

Fig. 20

13. Remove the two spacers from the worm gear shaft.

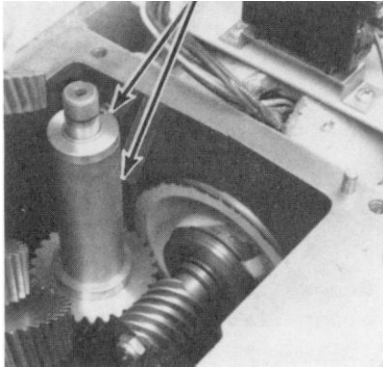

Fig. 21

14. Lift up on worm gear while turning motor (fan) to disengage gear from worm. Remove gear and key.

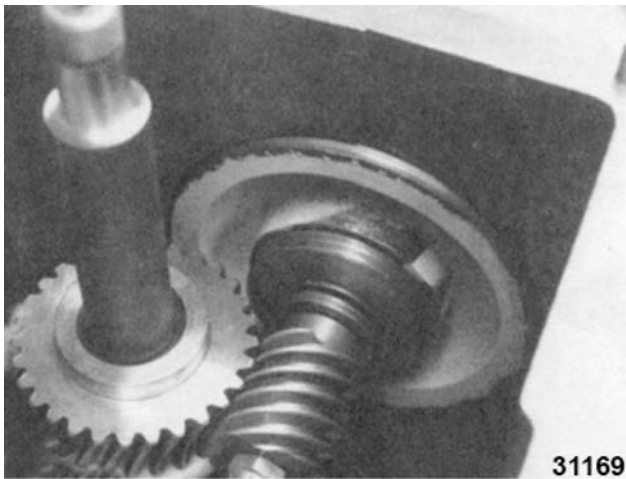

Fig. 22

15. Remove worm gear shaft.

PLANETARY SHAFT DISASSEMBLY

CAUTION

Keyways are very sharp. Handle shaft with care.

1. All parts from the lower clutch gear up, were removed while disassembling the transmission.
2. Take the shaft to an arbor press. Apply pressure to the planetary end and force the shaft through the lower planetary spacer, ball bearing, spacer and gear.
3. To remove clutch gear bushing, put shaft in arbor press and apply pressure to planetary end of shaft.

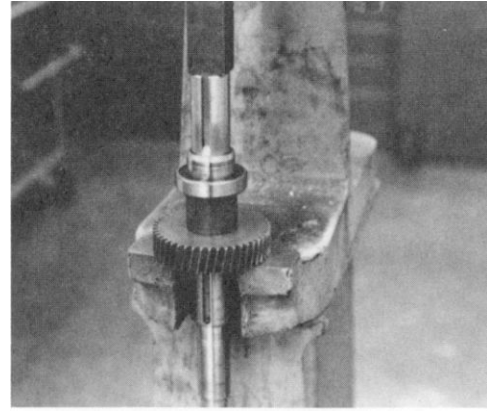

Fig. 23

PLANETARY SHAFT ASSEMBLY

1. If lower clutch gear bushing was removed, use arbor press to replace. Flange goes toward top of shaft.
2. Install lower clutch gear and bushing with collar of bushing and clutch teeth toward top of shaft.
3. Install spacer with smaller beveled edge against clutch gear.
4. Press bearing and lower spacer onto shaft until all end play is removed from clutch gear and spacer. Gear should turn freely.
5. The remainder of the parts will be assembled when the shaft is installed in the mixer.

NOTE: The o-ring is installed below the lower ball bearing and seats inside the hub seal.

TRANSMISSION SHAFT DISASSEMBLY

1. Remove retaining clip and remove lower bearing with a bearing puller.
2. Remaining parts can now be removed from shaft.
3. Reassemble in reverse order of removal.

NOTE: Gear lip (1, Fig. 24) faces inboard. Spacer (2, Fig. 24) goes between bearing and gear.

NOTE: Spacer (2, Fig. 24) has a chamfered edge. Chamfered edge faces bearing, squared edge faces gear.

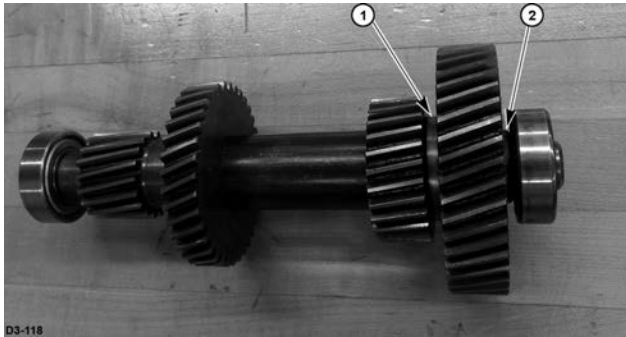

Fig. 24

TRANSMISSION ASSEMBLY

1. Install worm gear shaft (without worm gear).
2. Install key into worm gear shaft and install worm gear. Rotate motor to help engage worm gear to worm. Install spacers.
3. Install transmission shaft assembly and planetary shaft together. Be sure attachment drive gear is in place.
4. Install the following parts onto the planetary shaft in the order listed.

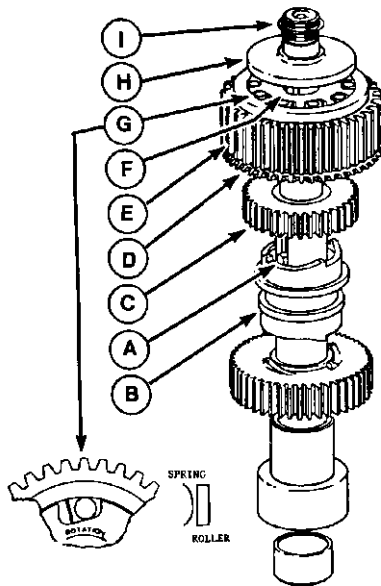

Fig. 25

- A. Keys (2).
- B. Clutch sleeve.

NOTE: Larger diameter faces up.

- C. Upper clutch gear and bushing.
- D. Key and bevel gear.
- E. Roller clutch gear (shoulder goes up).
- F. Drive sleeve (note top).

- G. Clutch rollers and springs.
- H. Upper planetary shaft spacer.
- I. Shims (1 to 3).

NOTE: Always install the same number of shims that were removed. If the number of shims is not known, install two shims and complete the assembly of the transmission. After transmission assembly is complete, test mixer as explained in "Planetary Shaft Shims", SERVICE PROCEDURES AND ADJUSTMENTS.

5. Install the shifter shaft and shifter yoke.
6. Install speed selector assembly.
7. Install speed selector cam.
8. Install cover plate and speed selector handle.
9. Add transmission grease.
10. Install transmission cover.
11. Install and tighten locknuts for planetary shaft and worm gear shaft. Install and bend up tabs of lockwashers.
12. If the worm gear shaft or any parts relating to the shaft were replaced, it may be necessary to adjust the worm gear shaft. Refer to "Worm Gear Shaft", SERVICE PROCEDURES AND ADJUSTMENTS.
13. Install planetary shaft and worm gear shaft bearing retainer covers.
14. Install planetary.
15. Install top cover, bowl and agitator.

SHIFTER UNIT

REMOVAL AND DISASSEMBLY OF SPEED SELECTOR

⚠ WARNING

DISCONNECT THE ELECTRICAL POWER TO THE MACHINE AT THE MAIN CIRCUIT BOX. PLACE A TAG ON THE CIRCUIT BOX INDICATING THE CIRCUIT IS BEING SERVICED.

1. Position the shifter handle in 1st speed and loosen set screw to remove handle.
2. Remove switch plate (4 screws).

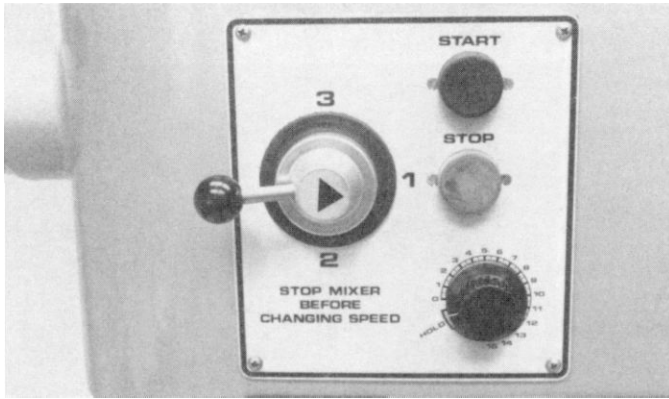

Fig. 26

3. Remove the speed selector cam.

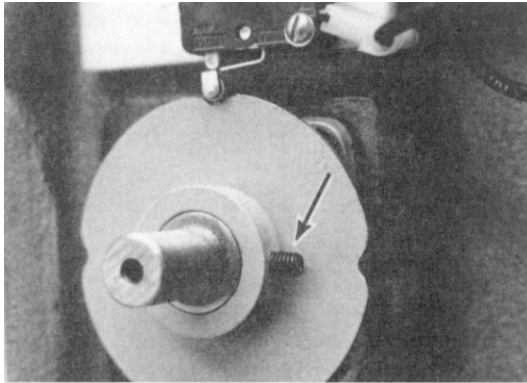

Fig. 27

4. Remove the speed selector assembly.
5. Drive out the rollpin.

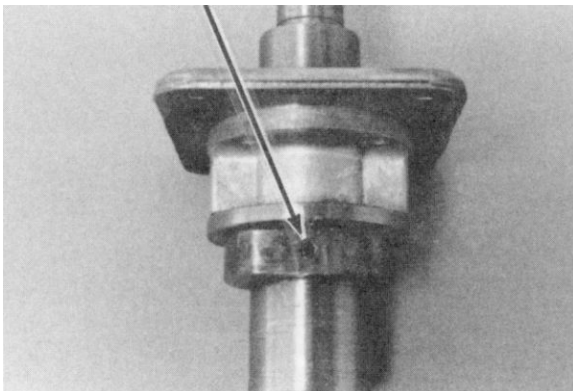

Fig. 28

6. Carefully separate the parts.

ASSEMBLY AND INSTALLATION OF SPEED SELECTOR

1. Install shifter shaft in index plate.
2. Install springs in index plate.
3. Place balls on springs.

4. Slip cam on shaft with the flat part of cam on the opposite side of shaft as dimple for shifter handle set screw.
5. Press assembly together and drive in rollpin.

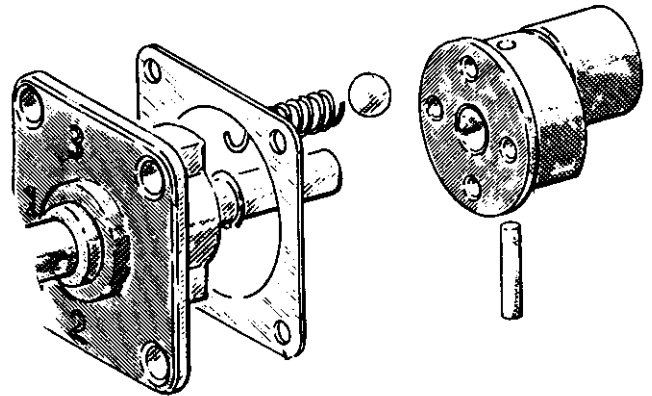

Fig. 29

6. Be sure gasket is in place and install assembly in the mixer.
7. Install the speed selector cam and check adjustment of speed selector switch. Refer to "Speed Selector Switch", SERVICE PROCEDURES AND ADJUSTMENTS.
8. Install switch plate and shifter handle.

REMOVAL AND DISASSEMBLY OF SHIFTER YOKE

⚠ WARNING

DISCONNECT THE ELECTRICAL POWER TO THE MACHINE AT THE MAIN CIRCUIT BOX. PLACE A TAG ON THE CIRCUIT BOX INDICATING THE CIRCUIT IS BEING SERVICED.

1. Complete Steps 1 thru 10 of Transmission Disassembly. Refer to "Transmission", this section.
2. To replace springs, remove retainer and remove spring. Both springs should be replaced to provide equal tension.

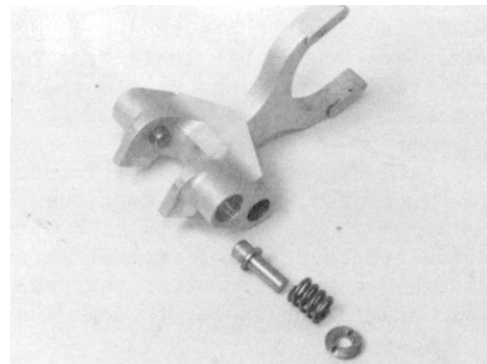

Fig. 30

3. Reassemble in reverse order of removal.

ATTACHMENT HUB

⚠ WARNING

DISCONNECT THE ELECTRICAL POWER TO THE MACHINE AT THE MAIN CIRCUIT BOX. PLACE A TAG ON THE CIRCUIT BOX INDICATING THE CIRCUIT IS BEING SERVICED.

Removal

1. When a unit is opened for the first time., the painted joint must be broken between the hub and transmission case. Run a knife point along the joint cutting through the paint. This helps to prevent a jagged joint.

NOTE: The three cap screws holding the attachment hub to the mixer are accessible inside the transmission case. Part of the transmission must be removed to gain access to the screws.

2. Complete Steps 1 thru 11 of Transmission Disassembly. Refer to "[Transmission](#)".
3. Remove three screws to remove attachment hub and bearing assembly out the front of the gear case and remove drive gear and thrust washer through inside of gear case.

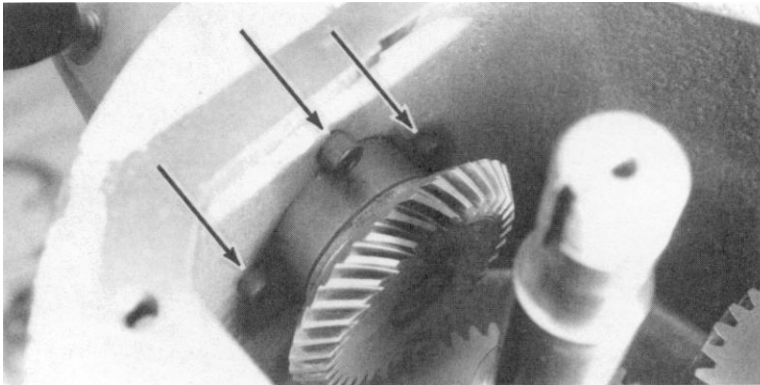

Fig. 31

4. Before installing the hub assembly, inspect the needle bearings and shaft seal.
5. Remove the old shaft seal and clean the seal cavity or if the needle bearings need replaced, press the bearings forward through the hub casting. Use an arbor press on wood block. Pressing out the bearings will also remove the oil seal.
6. Press new bearings into place making sure they are properly spaced.

7. Always use a new oil seal. A special Hobart Seal Installation Tool is available for easy installation of seals. Use of this tool permits a second or third seal to be used when required. Do not use more than three seals.
8. Reassemble in reverse order of disassembly. When installing the hub casting, use a small amount of Permatex to seal the hub casting to the transmission case.

COUNTERBALANCE SPRING

⚠ WARNING

DISCONNECT THE ELECTRICAL POWER TO THE MACHINE AT THE MAIN CIRCUIT BOX. PLACE A TAG ON THE CIRCUIT BOX INDICATING THE CIRCUIT IS BEING SERVICED.

Procedure

1. Remove bowl lift access cover.
2. Place bowl support in raised position.
3. Remove lower jam nut from bottom of bowl lift rod.

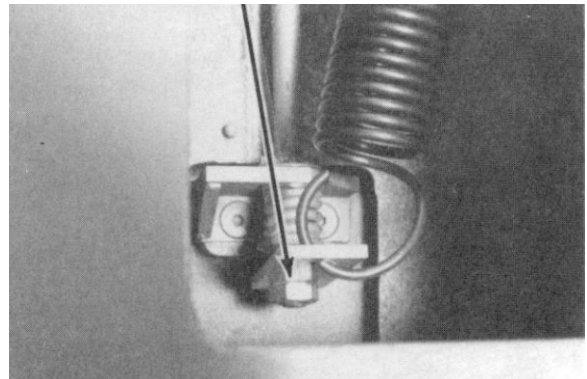

Fig. 32

4. Remove lower spring bracket from bowl lift rod.

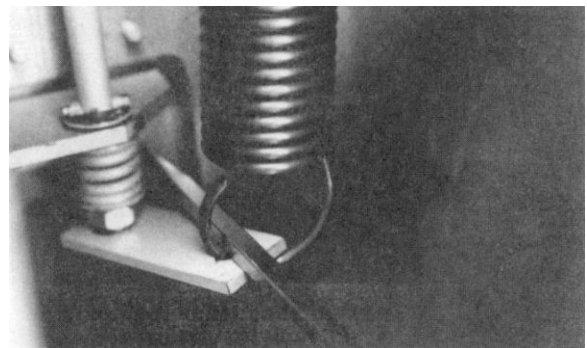

Fig. 33

5. Disconnect spring from upper bracket and remove.

- Reassemble in reverse order of removal.

NOTE: Install first jam nut until it is 3/8" beyond end of rod. Position lower spring bracket parallel with sides of mixer while tightening 2nd jam nut.

BOWL LIFT UNIT

BOWL LIFT HANDLE/BOWL LIFT ARM

⚠ WARNING

DISCONNECT THE ELECTRICAL POWER TO THE MACHINE AT THE MAIN CIRCUIT BOX. PLACE A TAG ON THE CIRCUIT BOX INDICATING THE CIRCUIT IS BEING SERVICED.

- Remove bowl and agitator.
- Remove bowl lift access cover.
- Remove counterbalance spring (see "Counterbalance Spring").
- With bowl support in raised position, knock out rollpin. Partially lower bowl support to remove completely.

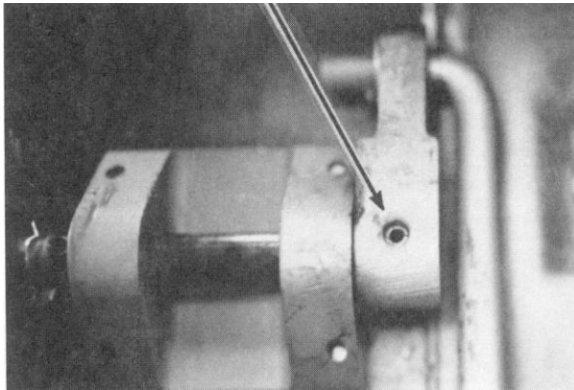

Fig. 34

- Remove rubber grommet.

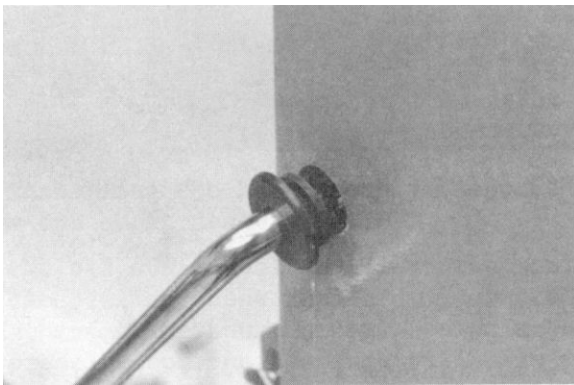

Fig. 35

- Remove handle (note spacer between handle rollpin and mounting bracket). If only the handle is being replaced, install new handle and reassemble in reverse order of removal. To remove bowl lift arm proceed to step 7.
- Remove rollpin and remove bowl lift arm.

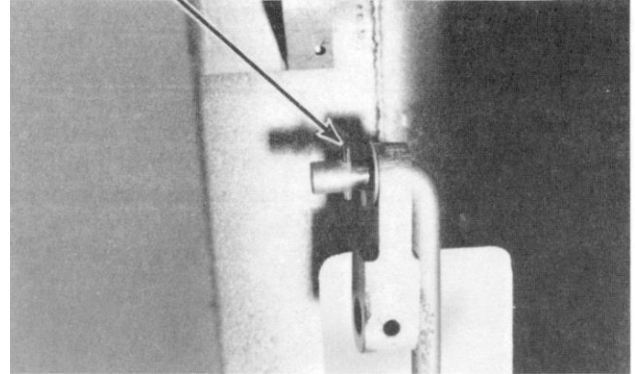

Fig. 36

- Reassemble in reverse order of removal.

BOWL LIFT ROD

⚠ WARNING

DISCONNECT THE ELECTRICAL POWER TO THE MACHINE AT THE MAIN CIRCUIT BOX. PLACE A TAG ON THE CIRCUIT BOX INDICATING THE CIRCUIT IS BEING SERVICED.

- Remove bowl and agitator.
- Remove bowl lift access cover.
- Remove counterbalance spring (see "Counterbalance Spring").
- Position the bowl support about half way down by placing a block of wood or other object under it.
- Knockout rollpin.

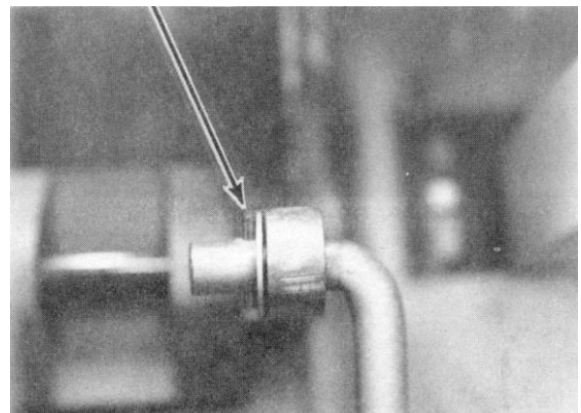

Fig. 37

- Remove jam nut. The flat washer, bowl lift spring and cupped washer will slide off the bowl lift rod.

7. Pull the bowl lift handle down. This will clear the bowl lift rod from the bowl support.
8. Remove the bowl lift rod.
9. Reassemble in reverse order of removal.

BOWL SUPPORT

REMOVAL

⚠ WARNING

DISCONNECT THE ELECTRICAL POWER TO THE MACHINE AT THE MAIN CIRCUIT BOX. PLACE A TAG ON THE CIRCUIT BOX INDICATING THE CIRCUIT IS BEING SERVICED.

1. Remove bowl and agitator.
2. Remove pedestal apron (4 thumb screws).

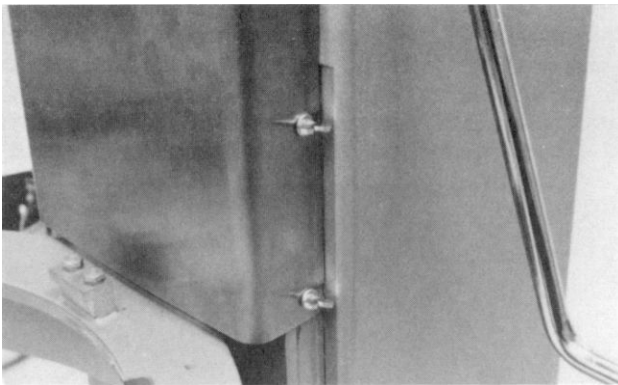

Fig. 38

3. Remove bowl lift access cover.
4. Remove counterbalance spring (see "[Counterbalance Spring](#)").
5. Place a support under bowl support and release tension on bowl lift handle.
6. Remove two cap screws that secure bowl lift bracket to bowl support.

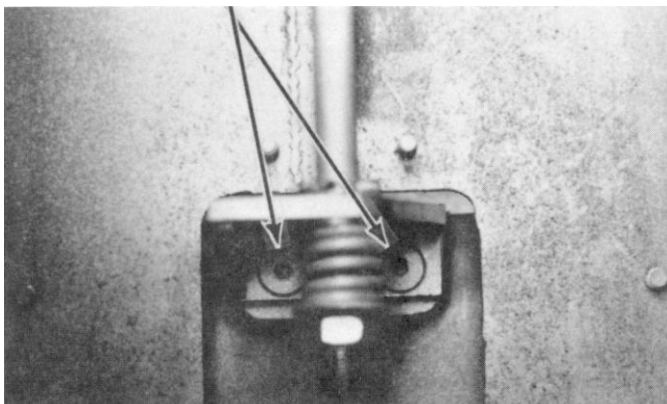

Fig. 39

7. Loosen the four screws securing the left hand gib.
8. Remove the four screws securing the right hand gib and remove gib.

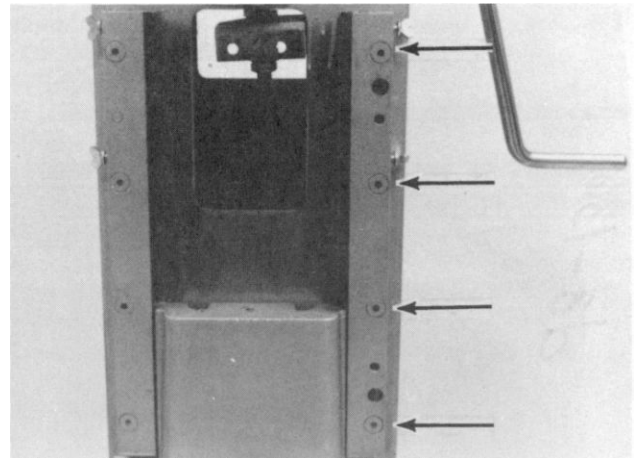

Fig. 40

9. Remove bowl support.

INSTALLATION

1. Prior to installing bowl support, note the two socket head set screws in the right hand gib. These are double set screws. Remove both top screws and loosen bottom screws until they no longer protrude from the rear.

NOTE: There may be a shim or shims between the inner and outer parts of the gibs. It should not be necessary to change the spacing unless the bowl support or the gibs are being replaced. In that case, install only enough shims to allow the bowl support to move up and down freely.

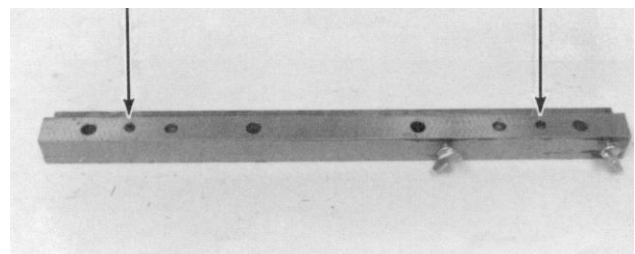

Fig. 41

2. Place bowl support in position and install right hand gib. Snug the cap screws.
3. Attach bowl lift bracket.
4. Raise bowl support. Place a .003" feeler gauge between bowl support and gib as shown. Using a thin block of wood (no more than 3/4" thick) and hammer, pound inner portion of gib toward bowl support. Tighten upper cap screw.

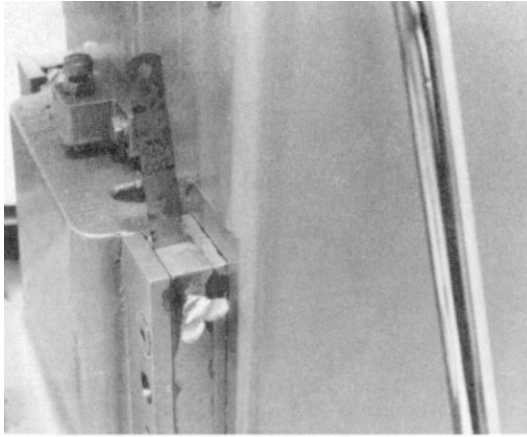

Fig. 42

5. Lower bowl support and repeat step 4 at lower end of gib. Tighten all cap screws.
6. Tighten upper and lower set screws. Install and tighten double set screws.
7. Install counterbalance spring and bowl lift access cover.
8. Install pedestal apron, bowl and agitator.

MOTOR

NOTE: Motor is too heavy to be removed by one person without mechanical assistance. If a hoist is not available, use two people to remove and install motor.

CAUTION

Worm has very sharp edges. Handle with care.

REMOVAL

⚠ WARNING

DISCONNECT THE ELECTRICAL POWER TO THE MACHINE AT THE MAIN CIRCUIT BOX. PLACE A TAG ON THE CIRCUIT BOX INDICATING THE CIRCUIT IS BEING SERVICED.

1. Remove top cover and motor access cover.
2. Drain transmission.
3. Disconnect motor wiring.
4. Remove component panel.

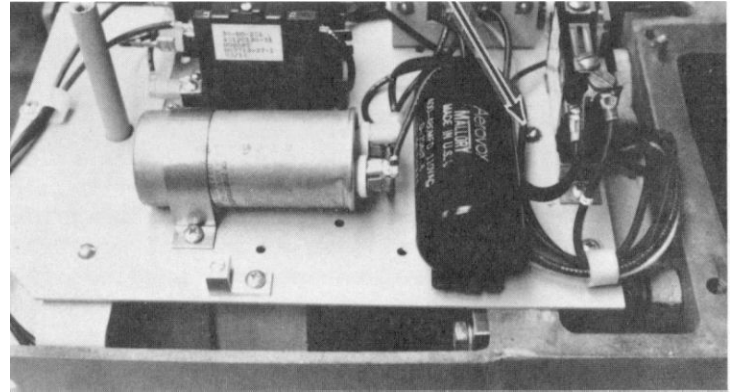

Fig. 43

5. Remove three mounting bolts. Access the lower mounting bolt by removing access cover.

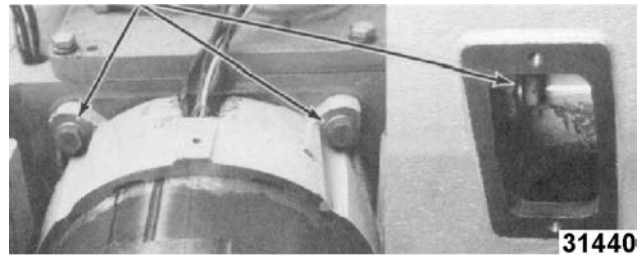

Fig. 44

6. Carefully disengage motor from transmission case and remove from mixer.

DISASSEMBLY

1. Remove fan cover and fan.

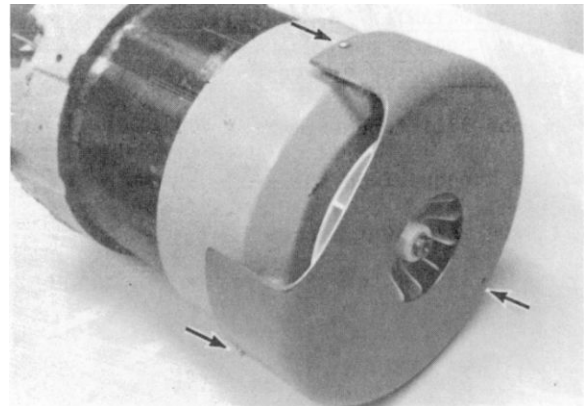

Fig. 45

2. Remove stop nut and remove worm using a bearing puller. Then remove Belleville washers and grease deflector.

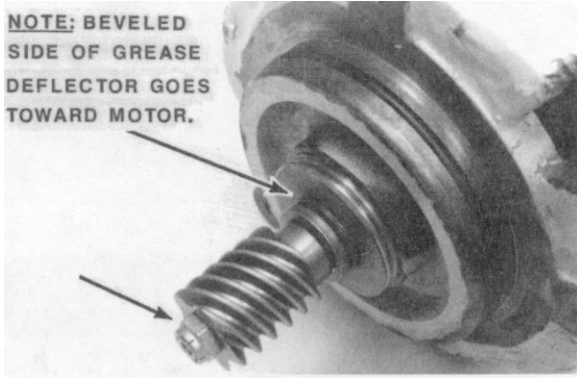

Fig. 46

3. Remove four bolts and separate rear bearing bracket from stator.

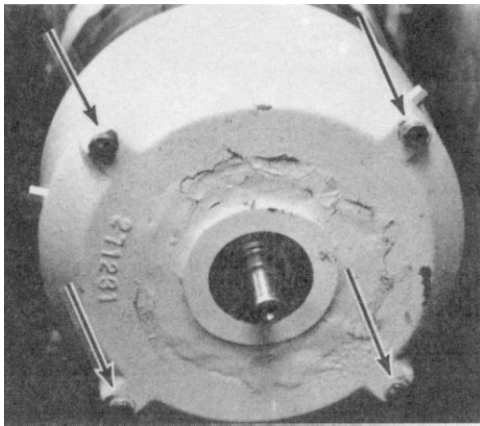

Fig. 47

4. Remove rotor. Note and remove wavy washer at worm end of rotor shaft.
5. Separate stator from front bearing bracket.
6. Replace bearings as necessary.
7. Single phase motors only.
 - A. Inspect stationary part of start switch for burned or pitted contacts. Replace if necessary.

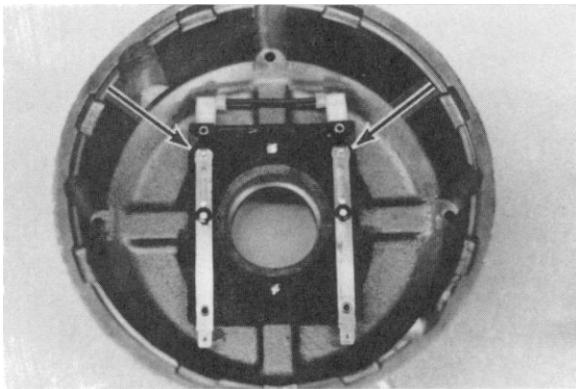

Fig. 48

- B. Rotating actuator switch replacement.

- 1) Scribe a line on the rotor shaft directly behind the actuator. This is important as the new actuator must be located on the shaft in exactly the same position as the old one.

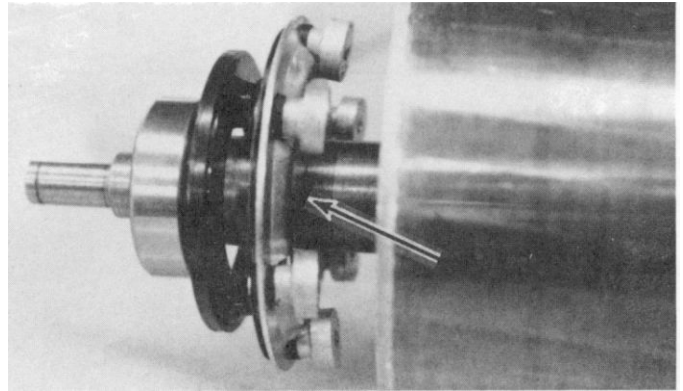

Fig. 49

- 2) Remove bearing and actuator with a puller.
 - 3) Install new actuator onto rotor shaft using a driving sleeve. Carefully align actuator to previously scribed line.
 - 4) Install bearings.
8. Reassemble in reverse order of disassembly.

INSTALLATION

1. Check that O-Ring is in place and in good condition. Replace if necessary. Apply a light film of oil to O-Ring before installing.

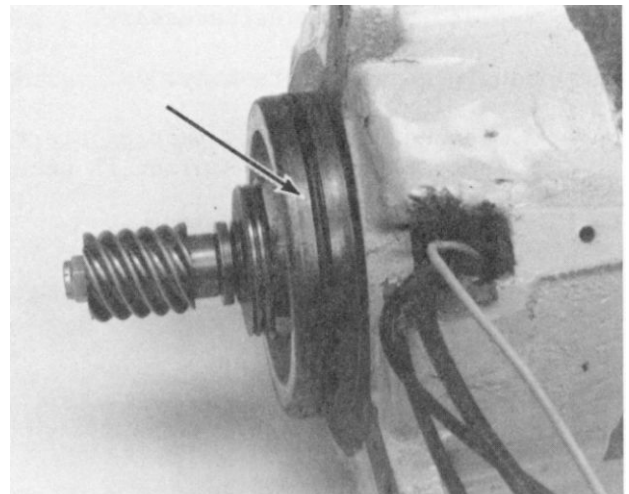

Fig. 50

2. Carefully place motor in position. Rotate motor fan while slowly positioning motor to ensure that worm is in mesh with worm gear. Install and tighten mounting bolts. Be sure motor turns freely.

3. Install component panel and connect motor wiring. Refer to section for wire connections.
4. Add transmission grease and install top cover and motor access cover.
8. Remove all remaining parts attached to pedestal and separate pedestal from base.
9. Reassemble in reverse order of disassembly.
10. Check bowl to beater clearance after assembly.

BASE AND PEDESTAL

REPLACING THE BASE

WARNING

DISCONNECT THE ELECTRICAL POWER TO THE MACHINE AT THE MAIN CIRCUIT BOX. PLACE A TAG ON THE CIRCUIT BOX INDICATING THE CIRCUIT IS BEING SERVICED.

1. A broken base can almost always be welded or brazed, often without removal from the mixer.
2. If removal or replacement is necessary, lay the mixer forward and rest on the attachment hub with wood blocks under each side of bowl support.
3. Remove four hex screws.
4. Use a knife to cut paint joint between base and pedestal.
5. Separate the base from the pedestal.
6. Reassemble in the reverse order of removal.

REPLACING THE PEDESTAL

WARNING

DISCONNECT THE ELECTRICAL POWER TO THE MACHINE AT THE MAIN CIRCUIT BOX. PLACE A TAG ON THE CIRCUIT BOX INDICATING THE CIRCUIT IS BEING SERVICED.

1. A mixer pedestal is replaced only because of breakage. If welding or brazing is practical, it is generally more economical than replacing the pedestal.
2. To remove, cut paint joints between pedestal and transmission case and base.
3. Remove top cover, motor access cover, bowl lift access cover and component panel.
4. Using a hoist to support transmission case and motor, remove six bolts securing transmission case to pedestal.
5. Separate transmission case and motor from pedestal.
6. Remove bowl support (see "Bowl Support").
7. Remove bowl lift handle, bowl lift arm and bowl lift rod (see "Bowl Lift Unit").

SERVICE PROCEDURES AND ADJUSTMENTS

BOWL ADJUSTMENTS

BOWL CLAMP ADJUSTMENT

1. The tension on the bowl clamps is regulated by a spring washer and stop nut.
2. To change the tension, tighten or loosen the stop nut.

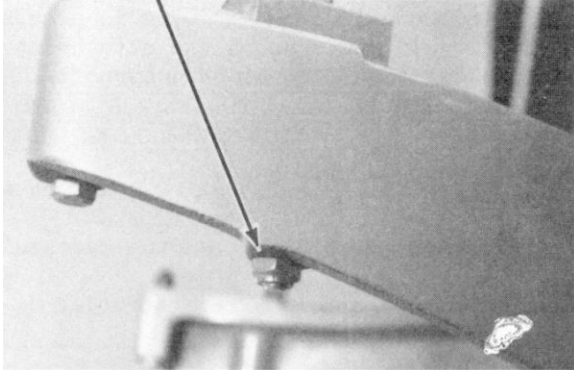

Fig. 51

BOWL LOCK ADJUSTMENT

⚠ WARNING

DISCONNECT THE ELECTRICAL POWER TO THE MACHINE AT THE MAIN CIRCUIT BOX. PLACE A TAG ON THE CIRCUIT BOX INDICATING THE CIRCUIT IS BEING SERVICED.

1. Remove the bowl lift access cover (see "Covers", REMOVAL AND REPLACEMENT OF PARTS).
2. When the bowl is raised, the lift handle will pass bottom center and stop when the bowl lift rod stops against the pedestal. Spring tension on the handle may be adjusted by turning jam nuts.

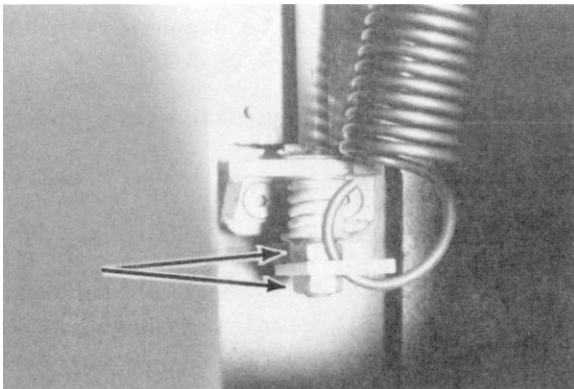

Fig. 52

BOWL TO BEATER CLEARANCE

⚠ WARNING

DISCONNECT THE ELECTRICAL POWER TO THE MACHINE AT THE MAIN CIRCUIT BOX. PLACE A TAG ON THE CIRCUIT BOX INDICATING THE CIRCUIT IS BEING SERVICED.

Clearance between the "B" beater and the bottom of the bowl should be .050" to .111".

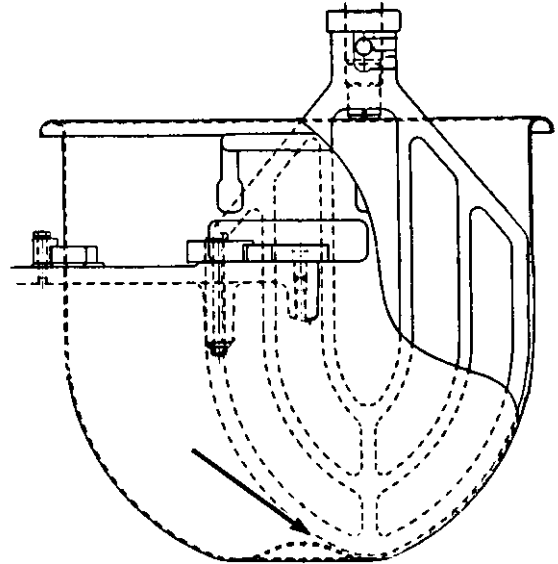

Fig. 53

1. Remove pedestal apron (4 thumb screws).
2. Lower bowl to its lowest position.
3. Loosen jam nut and adjust screw for desired clearance.

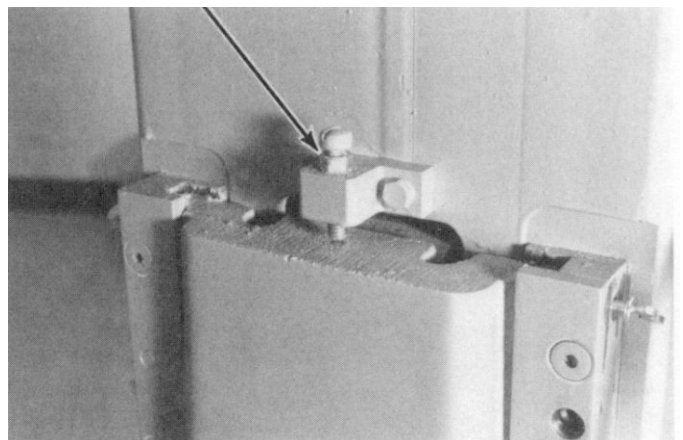

Fig. 54

4. Tighten jam nut and verify proper clearance.

5. Install pedestal apron.

BOWL SUPPORT

Gib Adjustment

There should be minimal side play of the bowl support in both the raised and lowered positions.

NOTE: There may be a shim or shims between the inner and outer parts of the gibs. It should not be necessary to change this spacing unless the bowl support or the gibs have been replaced. In that case install only enough shims to allow the bowl support to move up and down freely.

⚠ WARNING

DISCONNECT THE ELECTRICAL POWER TO THE MACHINE AT THE MAIN CIRCUIT BOX. PLACE A TAG ON THE CIRCUIT BOX INDICATING THE CIRCUIT IS BEING SERVICED.

1. Remove bowl and agitator.
2. Remove pedestal apron (4 thumb screws).
3. Note the two socket head set screws in the right hand gib. These are double set screws. Remove both top screws and loosen bottom screws.
4. Loosen the four screws securing the right hand gib.

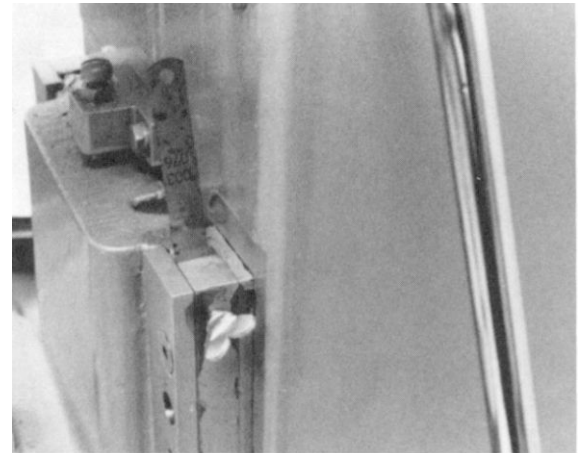

Fig. 56

6. Lower bowl support and repeat Step 5 at lower end of gib. Tighten all cap screws.
7. Tighten the two socket head set screws and install and tighten the double set screws over them.
8. Install pedestal apron, bowl and agitator.

WORM GEAR SHAFT

Adjustment Procedure

⚠ WARNING

DISCONNECT THE ELECTRICAL POWER TO THE MACHINE AT THE MAIN CIRCUIT BOX. PLACE A TAG ON THE CIRCUIT BOX INDICATING THE CIRCUIT IS BEING SERVICED.

1. Remove top cover and motor access cover (see "Covers", REMOVAL AND REPLACEMENT OF PARTS).
2. Remove the worm shaft bearing retainer cover.
3. Loosen the set screw that locks the adjusting sleeve.

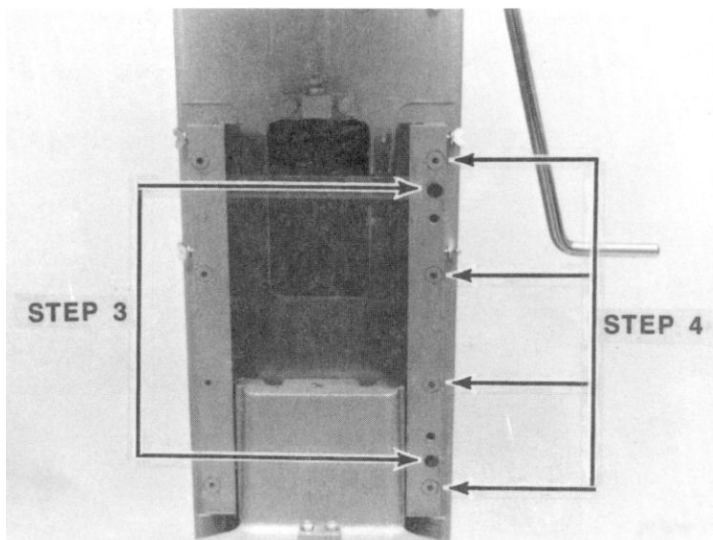

Fig. 55

5. With the bowl support in its raised position, place a .003" feeler gauge between the bowl support and gib. Using a thin block of wood (no more than 3/4" thick) and hammer, pound inner portion of gib toward bowl support. Tighten upper cap screw.

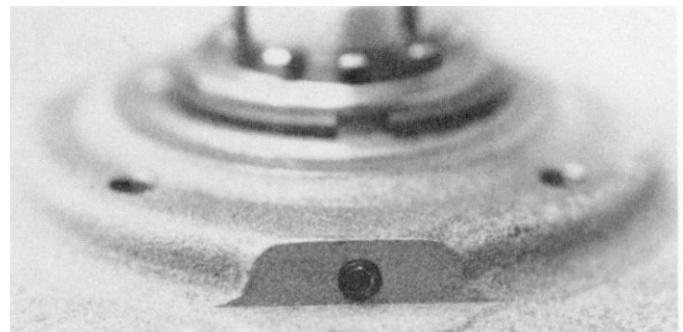
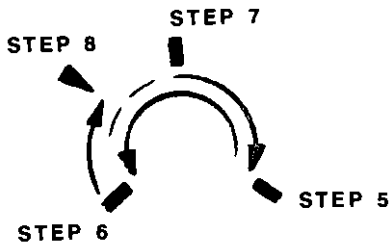

Fig. 57

4. Slowly turn the adjusting sleeve clockwise while turning the mixer motor fan by hand.

- When the motor shaft begins to bind mark the exact spot of the adjusting sleeve on the casting.



EXAMPLE ONLY, DISTANCES BETWEEN STEPS WILL VARY.

Fig. 58

- Turn the adjusting sleeve counterclockwise until the motor shaft again begins to bind and mark the exact spot of the adjusting sleeve on the casting.
- Measure halfway between the two extremes and mark the location.
- Turn the adjusting sleeve clockwise to midway between its position in Step 6 and the halfway mark. This positions the worm gear for best operation.
- Tighten the set screw to lock the adjusting sleeve in place.
- Replace the bearing retainer cover, housing covers and test mixer for proper operation.

PLANETARY SHAFT SHIMS

Spacing Procedure

There should be 1 to 3 thin spacers (.010" each) at the top of the planetary shaft. These spacers properly position the planetary shaft in relation to the shifter yoke. Improper spacing can result in the mixer not shifting properly when going from 2nd to 1st or from 3rd to 1st speeds. If the mixer does not shift speeds correctly, use the following procedure.

⚠ WARNING

DISCONNECT THE ELECTRICAL POWER TO THE MACHINE AT THE MAIN CIRCUIT BOX. PLACE A TAG ON THE CIRCUIT BOX INDICATING THE CIRCUIT IS BEING SERVICED.

- Remove top cover.
- Remove the planetary shaft bearing retainer cover.

- Bend down the tab on the lockwasher (2) and remove the locknut (1) and lockwasher.

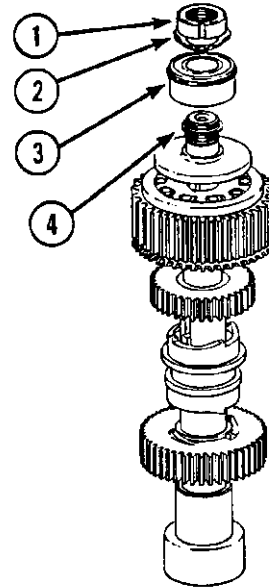

Fig. 59

- Remove the bearing (3) from the transmission.
- The spacers (4) are now accessible.
 - If the mixer will not shift from 2nd to 1st speed, remove a spacer.
 - If the mixer will not shift from 3rd speed to 1st speed, add a spacer.
- After adding or removing spacers, reassemble making sure the locknut (2) is tight. Connect power to mixer and test for proper shifting operation. Repeat procedure as necessary.

ATTACHMENT HUB BEVEL GEAR SPACING

There is a spacer between the attachment hub bevel gear and the transmission case. The size of this spacer is determined at the time of manufacture. There are six different spacers used ranging in size from .119" to .129".

The only time a spacer should have to be replaced would be if the attachment hub or transmission case was replaced or if the spacer was lost. In either of these cases, replace with a .125" spacer and test mixer. If noise from the bevel gears is excessive, the spacer is too large. Replace with a thinner one.

SPEED SELECTOR SWITCH

Adjustment Procedure

⚠ WARNING

DISCONNECT THE ELECTRICAL POWER TO THE MACHINE AT THE MAIN CIRCUIT BOX. PLACE A TAG ON THE CIRCUIT BOX INDICATING THE CIRCUIT IS BEING SERVICED.

1. Remove switch plate cover.



Fig. 60

2. Loosen switch mounting plate and position so that switch will operate half way up notch in cam surface.

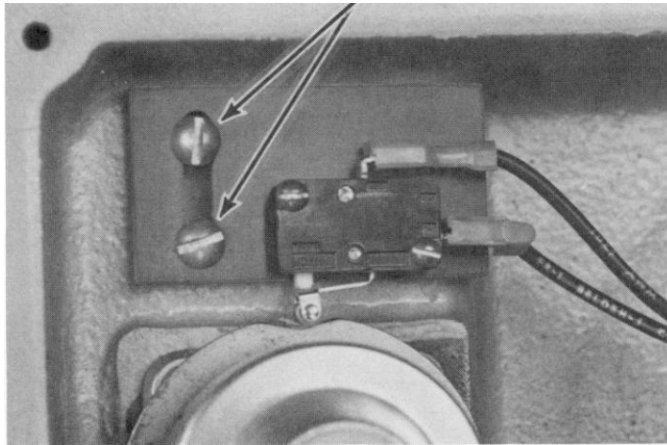

Fig. 61

TESTING MOTOR CURRENT

Procedure

NOTE: Before making a current check, be sure the correct voltage is being applied to the motor.

1. Turn off the power to the mixer.
2. Remove the top cover.
3. Clamp the amp tester around leads coming from contactor.
 - A. T1 or T2 - single phase.
 - B. T1, T2 or T3 - 3 phase.

4. Set the amprobe or adaptor to the appropriate range.
5. Turn on the power to the mixer and take reading, compare to chart. For 3 phase motors measure each leg.

NOTE: Should the motor overload protectors be open because of an overloaded condition, it will be necessary to wait until the overload thermal elements cool down before starting the motor.

MOTOR CURRENT CHART			
	OPERATING VOLTAGE	NOMINAL NO LOAD CURRENT	MAX. FULL LOAD CURRENT
Single Phase	120	18 amp	25.4
	208	11 amp	14.3
	240	9 amp	12.7
Three Phase	208	3 amp	5.8
	240	3-1/2 amp	5.4
	480	1-3/4 amp	2.7

Intermittent, short duration, overload currents no greater than 20% of the rated current are acceptable. Continuous currents above rated current or intermittent overload currents greater than 20% of the rated currents indicate an overloaded motor.

POWER FLOW DIAGRAMS

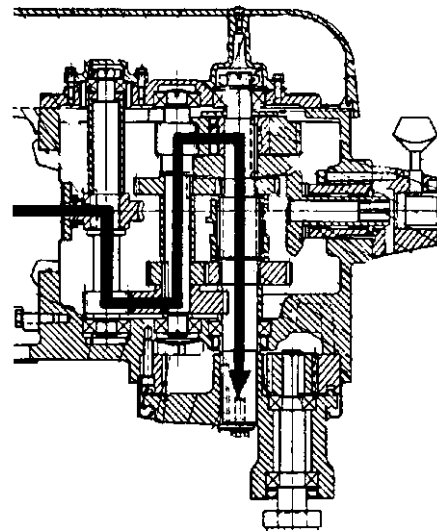

1ST SPEED

Fig. 62

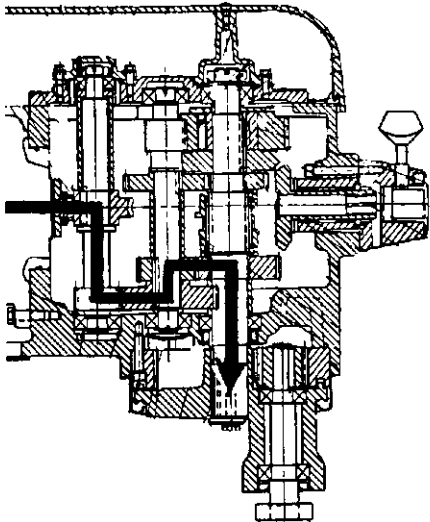

2ND SPEED

Fig. 63

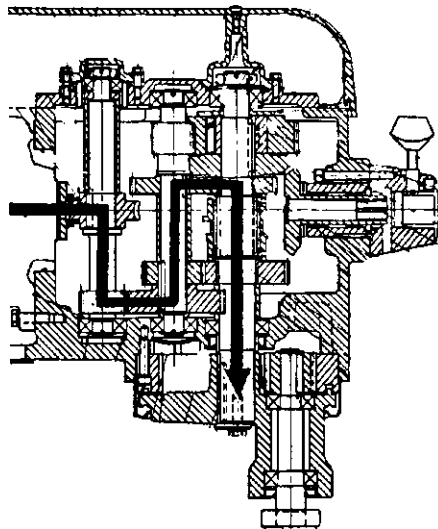

3RD SPEED

Fig. 64

ELECTRICAL OPERATION

COMPONENT FUNCTION CHART

MOTOR	Mixer Motor.
CON	Contactors, controls mixer motor.
TMR	Timer, automatically shuts off mixer when the time set has elapsed. Non-timed operation is obtained by setting dial to "Hold" position.
1PB	Stop switch.
2PB	Start switch.
LS	Limit switch, stops mixer if speed is changed while mixer is running.
SCAP	Motor start capacitor (single phase).
RCAP	Motor run capacitor (single phase).
T	Transformer, provides 115 V pilot circuit for mixers above 250V, 3 phase.
FU	Fuse, provides protection for pilot circuit (above 250V, 3 phase).
OL	Motor overloads.

COMPONENT LAYOUT

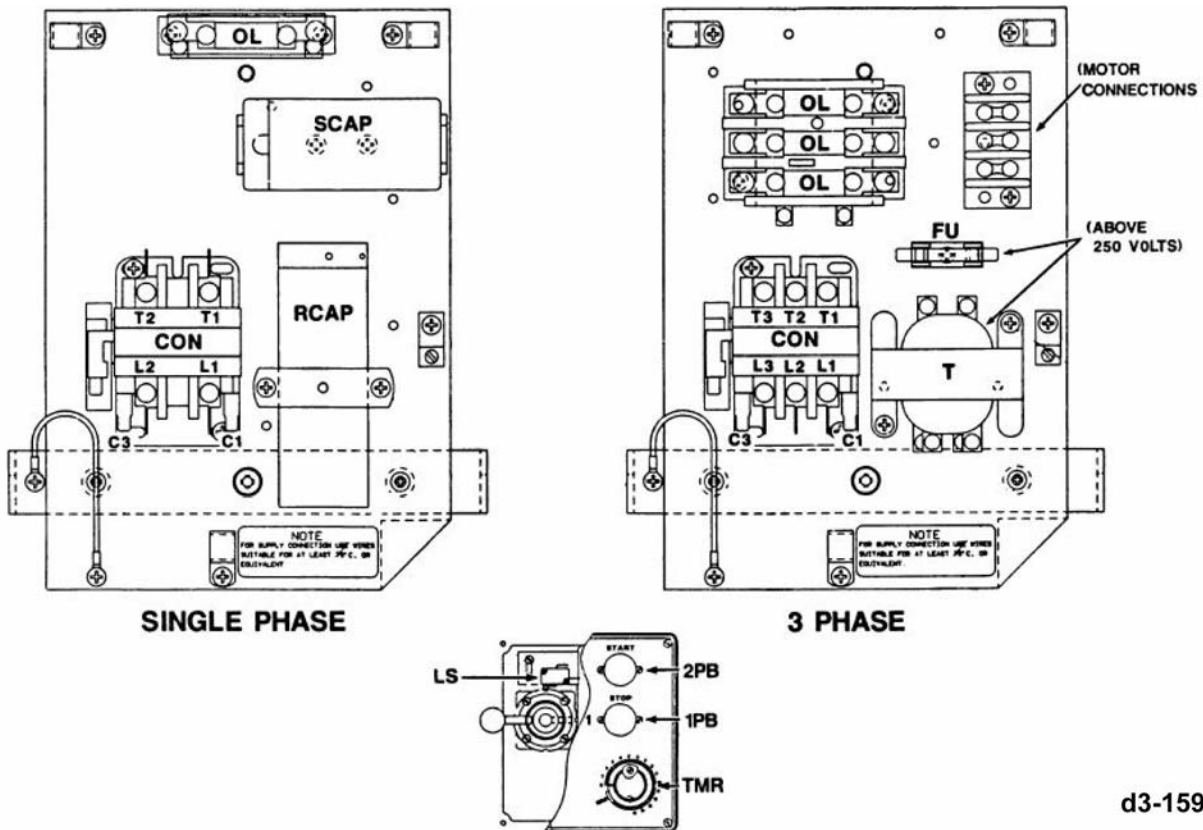

Fig. 65

d3-159

ELECTRICAL DIAGRAMS

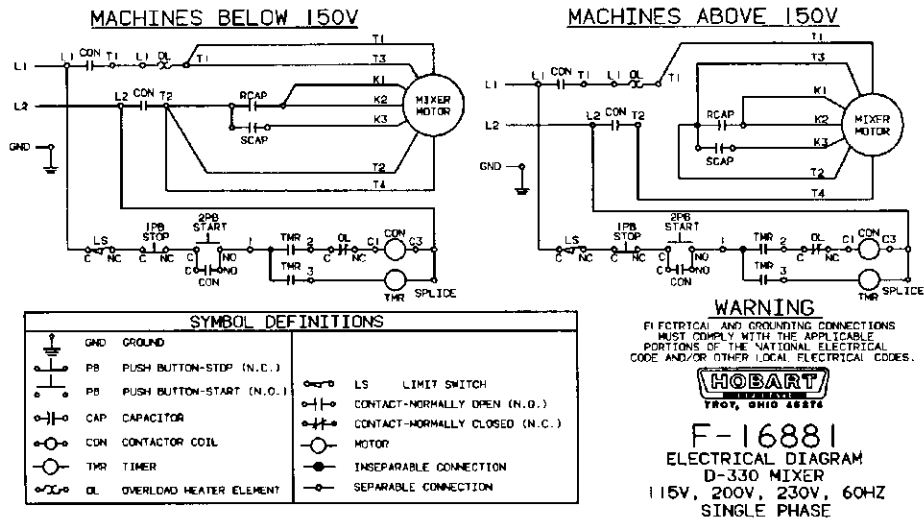

Fig. 66

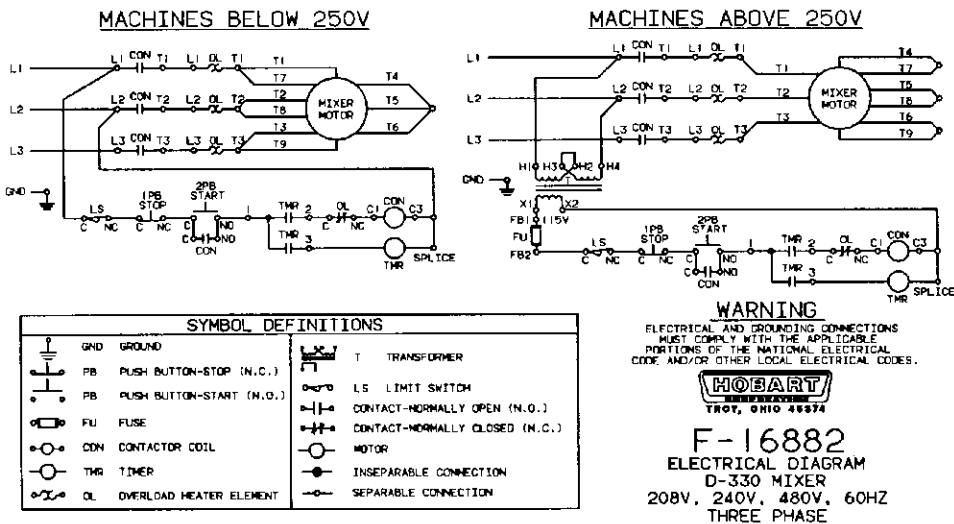

Fig. 67

TRUBLESHOOTING

TRUBLESHOOTING

MECHANICAL TROUBLESHOOTING	
SYMPTOMS	POSSIBLE CAUSES
Noise in transmission.	<ol style="list-style-type: none"> 1. Worn or damaged gears. 2. Improperly meshed gears. 3. Worn or broken keys. 4. Worn bearings. 5. Lack of lubrication.
Planetary does not turn in any speed.	<ol style="list-style-type: none"> 1. Key sheared: <ol style="list-style-type: none"> A. Worm on motor shaft. B. Worm gear shaft. C. Lower key of transmission shaft. D. Lower key of planetary shaft.
Agitator will not turn.	<ol style="list-style-type: none"> 1. Key sheared on pinion gear on agitator shaft. <p>See TSB 787B D330/D340/D340PFS - AGITATOR SHAFT ASSEMBLY/PLANETARY ASSEMBLY/ EXPANSION PLUG IMPROVEMENTS</p>
Attachment drive does not turn.	<ol style="list-style-type: none"> 1. Key sheared on attachment drive. 2. Key sheared on planetary shaft lower gear assembly.
Transmission does not shift from 2nd to 1st or 3rd to 1st speed.	<ol style="list-style-type: none"> 1. Planetary shaft spacing incorrect see "Planetary Shaft Shims", SERVICE PROCEDURES AND ADJUSTMENTS). 2. Planetary shaft locknut loose.
Grease leakage from planetary.	<ol style="list-style-type: none"> 1. Planetary shaft seal leaking. 2. Freeze plug leaking (bottom of transmission shaft).
Grease leakage near front of motor.	<ol style="list-style-type: none"> 1. Motor "O" ring seal pinched or cut.
Grease leakage at attachment hub.	<ol style="list-style-type: none"> 1. Attachment hub seal leaking. Can use up to three seals.

ELECTRICAL TROUBLESHOOTING	
SYMPTOMS	POSSIBLE CAUSES
Mixer motor runs only when start switch is depressed.	<ol style="list-style-type: none"> 1. Contactor C-NO contacts will not close.

ELECTRICAL TROUBLESHOOTING	
SYMPTOMS	POSSIBLE CAUSES
Mixer motor will not start.	<ol style="list-style-type: none"> 1. Incorrect power or no power to the machine. 2. Thermal overload open. 3. Speed selector switch open. <ol style="list-style-type: none"> A. Gear selector in between gears. B. Switch defective or improperly adjusted. 4. Start switch won't close. 5. Stop switch open. 6. Contactor coil open. 7. Timer contacts (1-2) open.
Mixer motor shuts off during operation.	<ol style="list-style-type: none"> 1. Motor overloads open. 2. Speed selector switch defective or improperly adjusted.
Mixer motor will not shut off at the end of a timed cycle.	<ol style="list-style-type: none"> 1. Timer malfunction.
Timer motor will not run.	<ol style="list-style-type: none"> 1. Timer Contacts (1-3) open. 2. Timer motor windings open.
Planetary rotates in wrong direction (3 phase mixers only).	<ol style="list-style-type: none"> 1. Interchange any two of the supply leads (L1, L2, L3) to the contactor (CON).



SERVICE

MISCELLANEOUS

VOL. 1 NO. 550B

April 20, 2005

TECHNICAL SERVICE BULLETIN

PRODUCT SERVICE DEPARTMENT

TROY, OH. 45374-0001

MACHINE DATE CODE INFORMATION

Introduction

Since January 1, 2002, all Hobart equipment, *except* microwave ovens, has been marked with a three-letter date code to eliminate duplication at the end of the two-letter date code numbering cycle (i.e. 23 assigned letters for a 23 year date code numbering cycle). The microwave ovens are marked with the month and year as outlined under Manufacture Date (item 2).

Between January 1985 and January 2001 all Hobart equipment, *except* microwave ovens, was marked with a two-letter date code.

Refer to manufacturing date code tables.

Manufacture Date

- All Hobart equipment is marked with a manufacturing date code in the CODE or MD section on the machine data plate with the exception of microwave ovens. If the CODE or MD section is not available, the manufacturing date code should be marked in the far right of the serial number section. The manufacturing date code will not become part of the serial number.

Exception: Refrigeration equipment is marked with the manufacturing date code directly following the serial number; or with the two-digit numerical date (Month & Year) in the DATE section.

- The microwave ovens are marked with a manufacturing date code in the section designated on the machine data label per UL 923. The month and year of manufacture are both marked without abbreviation, with the year shown as a four-digit number on the machine data label. Example: January 2005.

MANUFACTURING DATE CODES AFTER JANUARY 1, 2002					
*First Letter = Month	*Second and Third Letters = Year				
A = JAN	AA = 2001	AN = 2013	BB = 2025	BP = 2037	CC = 2049
E = FEB	AB = 2002	AP = 2014	BC = 2026	BR = 2038	CD = 2050
R = MAR	AC = 2003	AR = 2015	BD = 2027	BS = 2039	CE = 2051
P = APR	AD = 2004	AS = 2016	BE = 2028	BT = 2040	CF = 2052
Y = MAY	AE = 2005	AT = 2017	BF = 2029	BU = 2041	CG = 2053
U = JUN	AF = 2006	AU = 2018	BG = 2030	BV = 2042	CH = 2054
L = JUL	AG = 2007	AV = 2019	BH = 2031	BW = 2043	
G = AUG	AH = 2008	AW = 2020	BJ = 2032	BX = 2044	
T = SEP	AJ = 2009	AX = 2021	BK = 2033	BY = 2045	
C = OCT	AK = 2010	AY = 2022	BL = 2034	BZ = 2046	
N = NOV	AL = 2011	AZ = 2023	BM = 2035	CA = 2047	
M = DEC	AM = 2012	BA = 2024	BN = 2036	CB = 2048	
* The letters I, O, and Q have been omitted for clarity.					

NOTE: For the year 2001, each manufacturing facility had the option of using the last letter of **Y** in the two letter date code format or begin using the second and third letters of **AA** in the three-letter date code format (if space was available on the data plate).

MANUFACTURING DATE CODES BETWEEN JANUARY 1985 AND JANUARY 2001					
*First Letter = Month		*Second Letter = Year			
A = JAN	L = JUL	A = 1980	G = 1986	N = 1992	V = 1998
E = FEB	G = AUG	B = 1981	H = 1987	P = 1993	W = 1999
R = MAR	T = SEP	C = 1982	J = 1988	R = 1994	X = 2000
P = APR	C = OCT	D = 1983	K = 1989	S = 1995	Y = 2001
Y = MAY	N = NOV	E = 1984	L = 1990	T = 1996	
U = JUN	M = DEC	F = 1985	M = 1991	U = 1997	

* The letters I, O, and Q have been omitted for clarity.

3. Before 1985, GE or Chicago Heights cooking equipment serial numbers included a manufacturing date code. Serial number coding from 1962 to approximately 1984 for cooking equipment only.

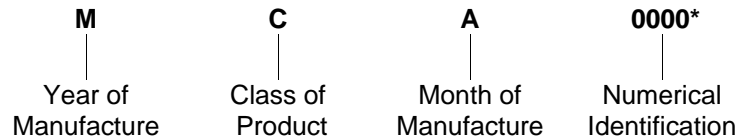

*From 1962 to 1963, the number of digits used may vary.

YEAR OF MANUFACTURE		YEAR OF MANUFACTURE		CLASS OF PRODUCT		MONTH OF MANUFACTURE	
Year	Letter	Year	Letter	Product	Letter	Month	Letter
1962	K	1974	B	Cooking	C	JAN	A
1963	L	1975	C	Refrigeration	R	FEB	B
1964	M	1976	D	Sanitation	S	MAR	C
1965	N	1977	E			APR	D
1966	P	1978	F			MAY	E
1967	R	1979	G			JUN	F
1968	S	1980	H			JUL	G
1969	T	1981	J			AUG	H
1970	U	1982	K			SEP	J
1971	W	1983	L			OCT	K
1972	X	1984	M			NOV	L
1973	A					DEC	M

SERIAL NUMBER CODING BEFORE 1962 FOR GE OR CHICAGO HEIGHTS EQUIPMENT ONLY								
	1954	1955	1956	1957	1958	1959	1960	1961
COOKING								
Heavy Equipment	4-0000	B-0000	F-0000	E-0000	C-0000	D-0000	G-0000	H-0000
Counter Equipment	4-0000	B-0000						
Griddles			BG0000	EG0000	CG0000	DG0000	GG0000	HG0000
Food Warmers			BF0000	EF0000	CF0000	DF0000	GF0000	HF0000
Fry Kettles			BK0000	EK0000	CK0000	DK0000	GK0000	HK0000
Waffle Bakers			BW0000	EW0000	C0000	DW0000	GW0000	HW0000
REFRIGERATION								
Water Coolers	24600000 to 24999999	55400000 to 55807000	70060000 to 70099999	70190000 to 70199999	70230000 to 70239999	70300000 to 70335000	70335700 to 70359100	70359101 to 70386665
SANITATION	Sanitation serial numbers will vary prior to 1968.							

TECHNICAL SERVICE BULLETIN

PRODUCT SERVICE DEPARTMENT

TROY, OH. 45374-0001

D330/D340/D340PFS - AGITATOR SHAFT ASSEMBLY/PLANETARY ASSEMBLY/EXPANSION PLUG IMPROVEMENTS

Current Improvements

- A double row bearing is being used on the upper end of the agitator shaft for improved reliability.
- The agitator shaft and shaft seal have been re-designed to accommodate the double row bearings.

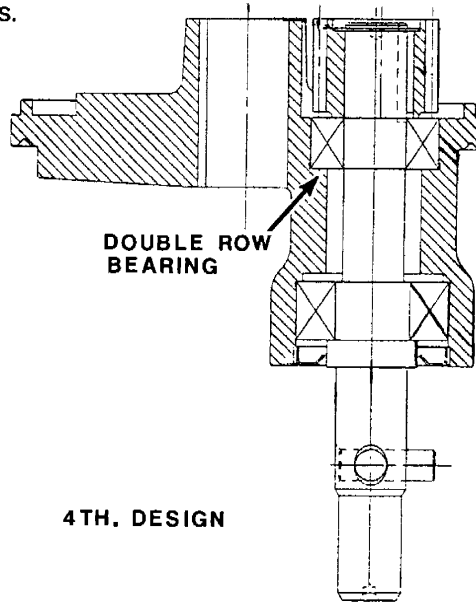

Previous Improvements

3rd. Design

1. A double row bearing was added on the lower end of the agitator shaft for improved reliability.
2. Two 3/8"-16 UNC-2B tapped holes, 3/4" deep were added to the planetary, so a bearing puller can be used for removal.

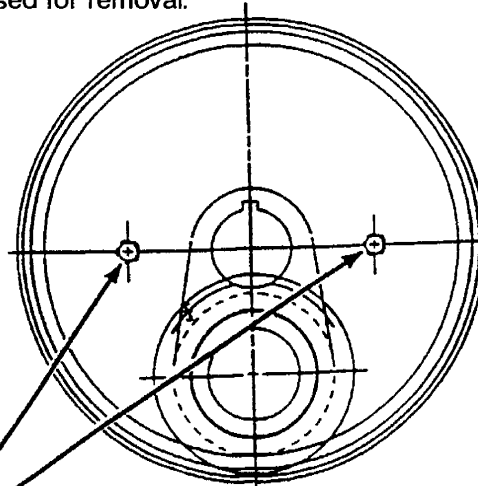

Continue Previous Improvements

3/8"-16 TAPPED HOLES

2nd. Design

1. The expansion plug hole was eliminated from the bottom of the transmission case. The expansion plug had occasionally fallen into the planetary gears.

NOTE: The expansion plug part no. PL-3-14 remains available for service.

2. The agitator shaft was shortened and the pinion gear counterbored. This allows the retaining ring to fit onto the shaft, but the shaft does not extend beyond the pinion gear. Interference between the agitator shaft and the transmission case was eliminated.

ORIGINAL PINION GEAR

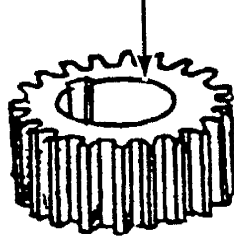

COUNTERBORED PINION GEAR

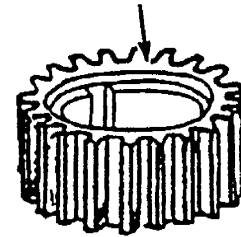

Reference Material Required

The information for any disassembly/assembly required to perform these instructions should be obtained from D330 Service Manual F-23771 (3/89)

Instructions

In order to use a bearing puller to remove the planetary, it will be necessary to locate the tapped holes and remove R.T.V. 109 and/or R.T.V. 732, Part No. 515194-2 and set screw Part No. SC-63-33. The set screw and R.T.V. 109 and/or R.T.V. 732 must be reinstalled.

Parts Information

Refer to the illustrations and chart below to determine which design is present and the service parts required.

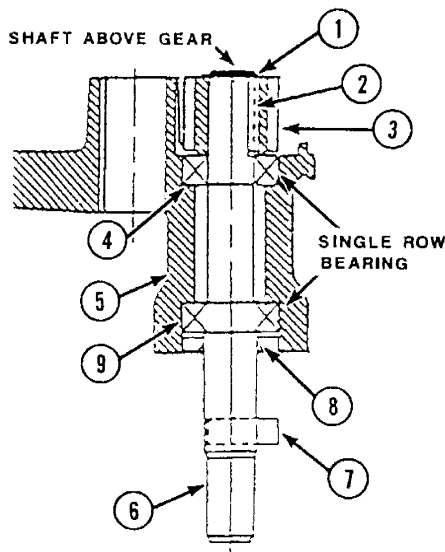

ORIGINAL DESIGN

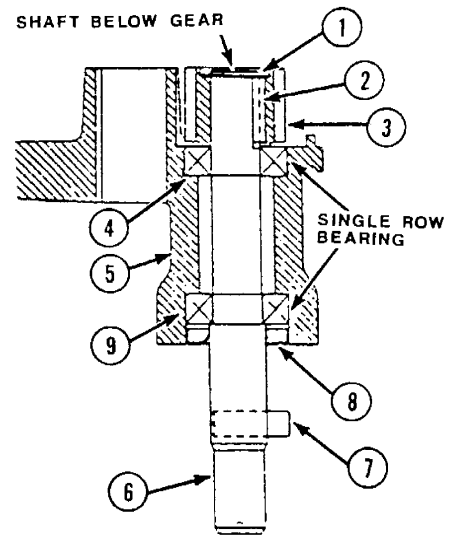

2ND. DESIGN

STARTING SERIAL NO. 11-439-909

Continue Parts Information

Parts Information Continued

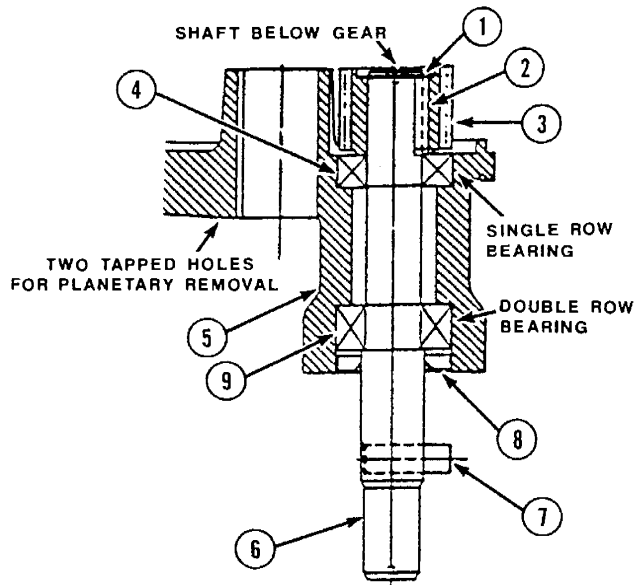

3RD. DESIGN
 STARTING SERIAL NO. D330 11-464-309
 D340 11-464-835
 D340PFS 11-465-659

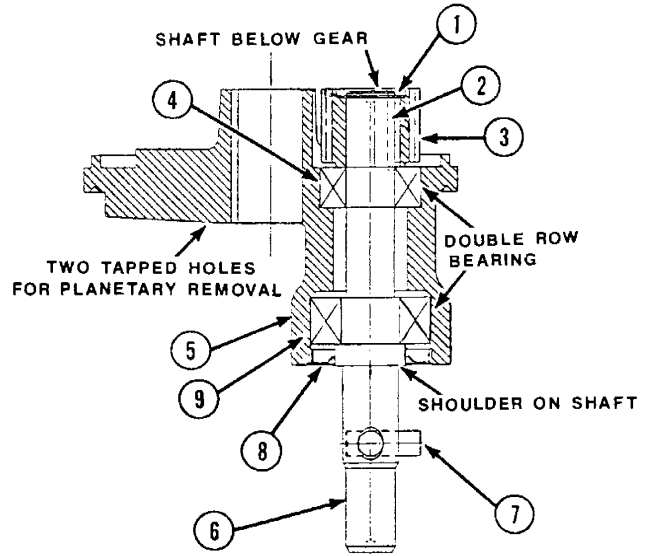

4TH. DESIGN

Illus. No.	Description	Original Part No.	Design				To Service, Order
			Orig.	2nd.	3rd.	4th.	
1	Retaining Ring	RR-9-19	x	x	x	x	RR-9-19
2	1/4" Sq. Key x 1-1/2" lg.	12430-158	x				12430-158
2	1/4" Sq. Key x 1-3/8" lg.	12430-180		x	x	x	12430-180
3	Pinion Gear	271249	x				439295 for Model D340PFS or 435548 & 437672 for Models D330 & D340
3	Counterbored Pinion Gear	435548		x	x	x	435548
4	Ball Bearing Single Row	BB-17-36	x	x	x		BB-17-36
4	Ball Bearing Double Row	BB-21-34				x	BB-21-34
5	Planetary (Painted)	271220-2-1	x				439295 for Model D340PFS or 438230 for Models D330 & D340
5	Planetary (Painted)	271220-2-3		x	x		439295 for Model D340PFS or 438230 for Models D330 & D340
5	Planetary (Painted)	438240-2				x	438240-2

Illus. No.	Description	Original Part No.	Design				To Service, Order
			Orig.	2nd.	3rd.	4th.	
6	Agitator Shaft Assembly (includes item 7)	271246	x				439295 for Model D340PFS or 437672 for Models D330 & D340
6	Agitator Shaft Assembly (includes item 7)	435550		x			439295 for Model D340PFS or 437672 for Models D330 & D340
6	Agitator Shaft Assembly (includes item 7)	437672			x		439295 for Model D340PFS or 437672 for Models D330 & D340
6	Agitator Shaft Assembly (includes item 7)	438229				x	438229
7	Agitator Pin	70019	x	x	x	x	70019
8	Agitator Shaft Seal	110335	x	x	x		110335
8	Agitator Shaft Seal	439286				x	439286
9	Ball Bearing Single Row	BB-17-36	x	x			BB-17-36
9	Ball Bearing Double Row	BB-21-31			x		BB-21-31
9	Ball Bearing Double Row	BB-21-35				x	BB-21-35
--	Planetary Assembly (includes items 1-9)	271326	x				439295 for Model D340PFS or 438230 for Models D330 & D340
--	Planetary Assembly (includes items 1-9)	435551		x			439295 for Model D340PFS or 438230 for Models D330 & D340
--	Planetary Assembly (includes items 1-9)	437671			x		439295 for Model D340PFS or 438230 for Models D330 & D340
--	Planetary Assembly (includes items 1-9)	438230				x	438230
--	Internal Gear	271250-2	x	x			439295 for Model D340PFS or 439291-2 for Models D330 & D340
--	Internal Gear	438473			x		439295 for Model D340PFS or 439291-2 for Models D330 & D340
--	Internal Gear	439291-2				x	439291-2
--	Planetary Assembly & Internal Gear Kit (includes Planetary Assembly Part No. 438230 and Internal Gear Part No. 439291-2)	439295				x	Order as called for in the chart

TECHNICAL SERVICE BULLETIN

PRODUCT SERVICE DEPARTMENT

TROY, OH. 45374-0001

D330/D340/D340PFS MIXERS - FRONT MOTOR HOUSING SEAL, "O" RING, AND HUB SEAL "O" RING ENHANCEMENTS - LOW LUBRICATION SYMPTOMS

Purpose

Current production of these models have the latest enhancement, which is a seal in the front motor housing. The new front motor housing/seal assembly can be identified by looking for a groove cut in the top of the three mounting lugs.

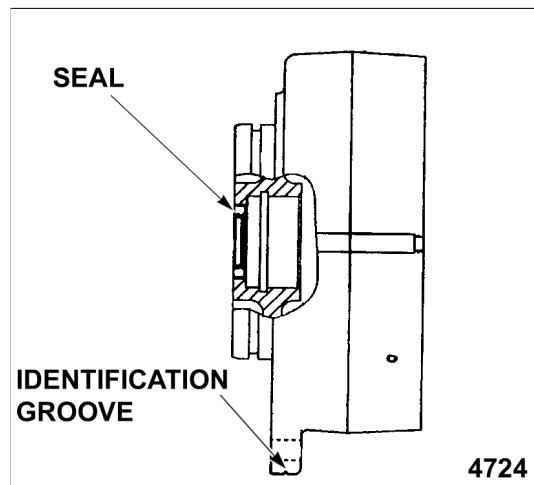

Reference Material

NOTE: The information for any disassembly/assembly required to perform these instructions should be obtained from D330 service manual, F-23771 (3/89) and this bulletin.

Symptoms

1. Overload relay(s) cutting off.
2. Grease leak(s).
 - A. Out of reed switch housing (units with bowl guard).
 - B. Between pedestal and base.
 - C. At bottom of the planetary shaft.
3. Low transmission lubrication.

Possible Causes

1. Low transmission lubrication can create a mechanical condition where the motor ampere draw causes the overload relay(s) to trip.
2. Air pressure in the transmission can cause a leak and /or a breakdown of the lubrication.
3. Lack of an "O" ring in the planetary shaft sub-assembly and/or lack of an "O" ring and a seal in the front motor housing.

Solution

- The factory on a temporary basis drilled a 1/8" hole in the friction plug in the transmission case cover assembly. This provides an air vent for the transmission. Current production units have the air vent in the transmission case cover assembly.

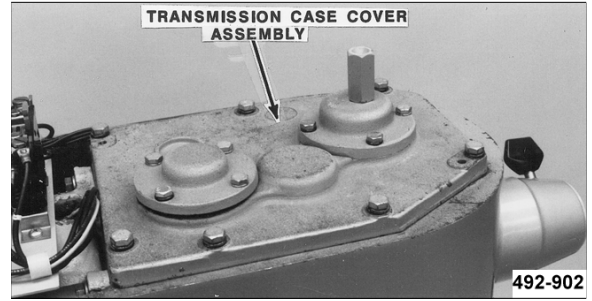
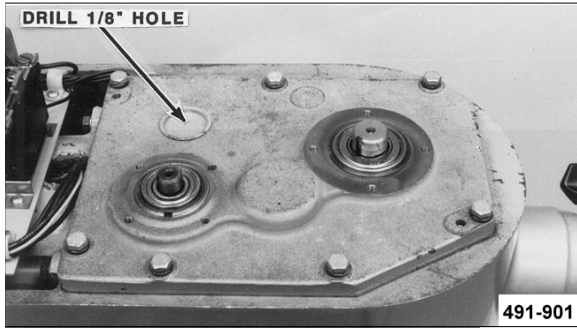

- The transmission lubrication has changed to Chevron FM O and is 9 lbs.
The proper lubrication amount brings the level to the center line of the motor worm gear when mixer is running and lubricant is warm. The lubrication level can be observed by removing the friction plug.
- An "O" ring enhancement was made to the hub seal of the planetary shaft sub-assembly.
- An "O" ring and seal enhancement was made to the front motor housing.

Instructions

1. Repair any grease leak(s).
 - A. If a leak from the bottom of the planetary shaft is present determine the parts required from the following chart and install them per the illustration shown.

Previous Part Number	Description	To Replace Use	Qty
274040	Planetary Shaft Sub-Assembly	437603	1
271224	Hub Seal	437599 and	1
-----	"O" Ring	67500-70	1

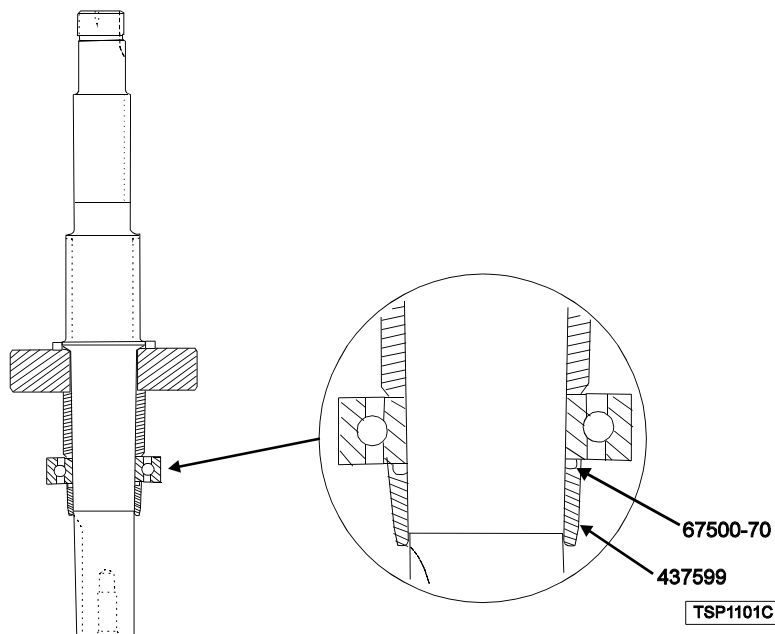

- B. If grease was observed running from under the mixer, out of the reed switch housing (units with bowl guard) or between the pedestal and the base, it may be necessary to remove and disassemble the motor for removal of any grease present. If grease is present, clean the motor and order the front motor housing/seal assembly, part # 873505-2 and "O" ring, part # 67500-126.
- 1) Install the parts per the illustration shown.

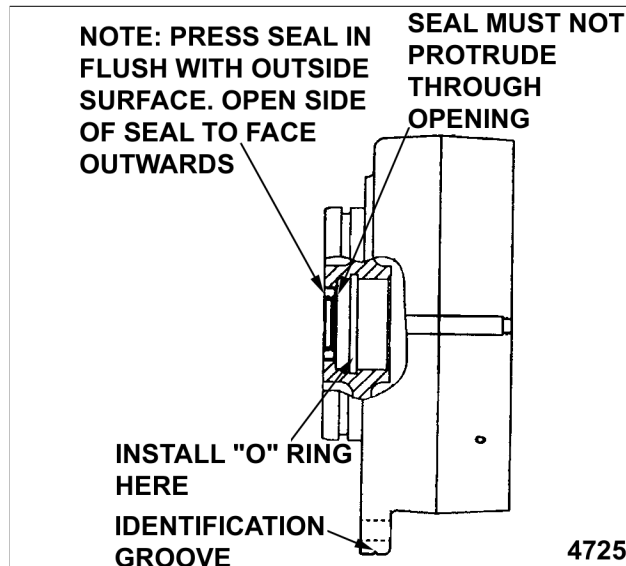

NOTE: Anytime the previous front motor housing, part # 271254-2 is ordered, the front motor housing/seal assembly part # 873505-2 will be sent. The "O" ring part # 67500-126 must be ordered and installed.

Once the front motor housing/seal assembly is present, the individual seal part # 873508 can be ordered as a service part.

2. Check to see if an air vent is present in the friction plug or the transmission case cover assembly. If none is present, remove the friction plug and hand drill a 1/8" hole in the center.
3. Remove the grease and clean the transmission case. Inspect the components for any needed replacement.
4. Partially fill the transmission case with Chevron FM O to the level where the bottom of the motor worm gear will run in the lubrication.
5. Run the mixer and transmission for approximately ten minutes or until the transmission is warm and the grease is moving easily. This allows the lubrication to settle into the transmission.
6. Top off the lubrication by adding Chevron FM O until level with the center line of the motor worm gear and/or 9 lbs. have been installed.
7. Reassemble mixer and check for proper operation and leaks.



TECHNICAL SERVICE BULLETIN

PRODUCT SERVICE DEPARTMENT

TROY, OH. 45374-0001

D300 UPDATE KITS - PART NOS. 438820-1, -2, -3 & -4

Introduction

These kits are designed to update an untimed D300 mixer built without a contactor, to an untimed mixer with a contactor and overload relay.

Electrical Application Information

KIT PART NO.	ELECTRICAL APPLICATION
438820-1	115V/60 Hz./1 Phase, 115V/50 Hz./1 Phase
438820-2	200V/60 Hz./1 Phase, 230V/60 Hz./1 Phase, 220V/50 Hz./1 Phase
438820-3	230V/60 Hz./3 Phase, 200V/60 Hz./3 Phase, 220V/50 Hz./3 Phase
438820-4	460V/60 Hz./3 Phase, 380V/50 Hz./3 Phase, 415V/50 Hz./3 Phase

Parts Information

---- indicates part is not a service replacement part.

PART NO.	DESCRIPTION	QTY.	KIT NO.
----	Control Panel Assembly	1	All
102467-1	Cap - Push Button (Start)	1	All
102467-2	Cap - Push Button (Stop)	1	All
87711-183-1	Station - Push Button (Start) (Black)	1	All
87711-183-2	Station - Push Button (Stop) (Red)	1	All
NS-10-11	Hex Nut 8-32	2	All
WL-11-01	Lockwasher	5	All
SC-27-28	Machine Screw 8-32 x 1/4" (Brass)	2	All
65890-21	Terminal	6	All
65890-29	Insulated Connector	1 1	438820-1 438820-2
110961	Shifter Handle Grommet	1	All
SC-13-12	Mach. Screw 6-32 x 1/4" Flat Hd.	4	All
291723	Plate - Switch	1	All
----	Start Switch Wiring Harness	1	All
----	Lead Wire Assemblies	As Required	All
112235-17	Overload Heater Element	3	438820-4
112235-24	Overload Heater Element	3	438820-3
112235-32	Overload Heater Element	1	438820-2
112235-33	Overload Heater Element	1	438820-2

Continue
 Parts Information

Parts Information
Continued

PART NO.	DESCRIPTION	QTY.	KIT NO.
112235-40	Overload Heater Element	1	438820-1
112235-59	Overload Heater Element	1	438820-1
F-14589	Wiring Diagram	1 1	438820-1 438820-2
F-14590	Wiring Diagram	1 1	438820-3 438820-4
SC-007-37	Machine screw 8-32 x 1/4" (Steel)	3 3	438820-3 438820-4
65890-23	Butt Splice	6	All
502374	Wire	2 FT.	All
F-19167	Wiring Diagram	1 1	438820-1 438820-2

The individual service part numbers available for the control panel assembly can be found in the Catalog of Replacement Parts F-16971 (10/88) pages 8, 9, 18 and 19. The wiring diagrams can be ordered from the Literature Center, Troy, OH.

Special Tools Required

- Suggested crimping tool, T & B No. WT-111-M or Amp No. 47386
- No. 33 Electrical Tape, part no. 508494

Installation Instructions

WARNING: DISCONNECT THE ELECTRICAL POWER TO THE MACHINE AT THE MAIN CIRCUIT BOX. PLACE A TAG ON THE CIRCUIT BOX INDICATING THE CIRCUIT IS BEING SERVICED.

1. Remove shifter handle assembly and grommet. Discard grommet.
2. Remove switch plate screws (save screws).
3. Disconnect switch wiring and discard switch plate with switch.
4. Tilt mixer forward and block up back legs 3-1/2" to 4" to prevent grease leakage at motor opening.
5. Remove trim cap.
6. If unit is single phase and has a stationary start switch, disconnect wires.
7. Remove bearing bracket with bearing cap and rotor by removing four screws.
8. Remove lead wire retainer.

Continue Installation Instructions

9. Remove cover and gasket assembly (capacitor and starter access).

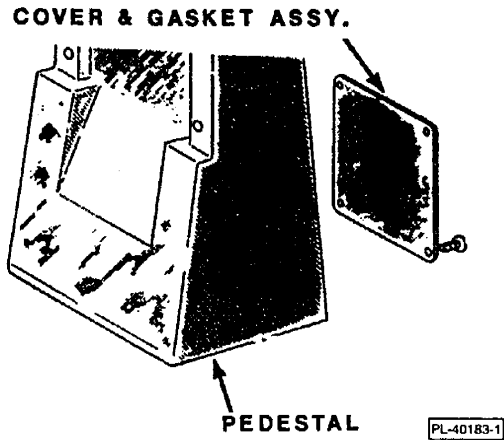

10. If unit is single phase, disconnect wiring to capacitor and electronic start switch (if present).
 - A. Remove screws and washers holding capacitor mounting plate to pedestal and save them.
 - B. Discard mounting plate with capacitor and electronic start switch (if present).
11. Install the proper overload heater element(s) (as listed below) in the overload relay on the control panel assembly.

ELECTRICAL APPLICATION	OVERLOAD HEATER ELEMENT PART NO.	VENDOR NO.	QTY.
115V/60 Hz./1 Phase	112235-59	E-54	1
115V/50 Hz./1 Phase	112235-40	E-53	1
200V/60 Hz./1 Phase	112235-33	E-46	1
230V/60 Hz./1 Phase	112235-33	E-46	1
220V/50 Hz./1 Phase	112235-32	E-44	1
230V/60 Hz./3 Phase	112235-24	E-33	3
200V/60 Hz./3 Phase	112235-24	E-33	3
220V/50 Hz./3 Phase	112235-24	E-33	3
460V/60 Hz./3 Phase	112235-17	E-24	3
380V/50 Hz./3 Phase	112235-17	E-24	3
415V/50 Hz./3 Phase	112235-17	E-24	3

Continue Installation Instructions

12. If the unit is single phase and originally had an electronic start switch, reconnect the wiring to the capacitor and electronic start switch on the control panel assembly.

- A. If the unit has a stationary start switch, remove and discard the electronic start switch, and the lead wire assemblies from the capacitor to the electronic start switch and from the electronic start switch to the contactor.

NOTE: It may be necessary to extend the existing wires by using the butt splices and wire provided.

- (1) Reconnect existing wires to capacitor.

13. Install the lead wire assemblies and the start switch harness to the control panel components per the proper new wiring diagram and the branding on the wires.

NOTE: It may be necessary to loosen the top contactor mounting screw to swing the contactor out of the way so the control panel assembly will pass through the opening in the pedestal.

14. On a single phase unit ,install control panel assembly where capacitor mounting plate was removed using screws and washers saved in step 10A.

15. On a three phase unit, install control panel assembly at three tapped holes in pedestal at back of cavity, using 8-32 x 1/4" machine screws (Steel) and lockwashers in kit.

16. Assemble the start switch and stop switch to the switch plate using four screws provided.

- A. Install the proper switch cap on each switch.

17. Route and connect the lead wire assemblies and start switch harness from the control panel assembly per the proper new wiring diagram and the branding on the wires.

- A. The connections to motor leads with ring terminals should be made using the 8-32 x 1/4" screws (Brass), washers and nuts provided. Tape the connections.

- (1) On a single phase motor with quick connect leads an insulated connector must be installed between the T4 motor lead and the lead wire assembly to the overload T1.

- B. Any cord and plug or line connections to the contactor should be re-terminated using the terminals provided.

- C. The existing lead wires from the old on/off switch should be pulled and discarded.

18. Install the switch plate assembly using screws saved in step 2.

19. Peel the backing from the proper wiring diagram and place over the original wiring diagram.

20. Reassemble the mixer in reverse order steps 9-4 and 1, installing the new grommet at step 1.

21. Power mixer and check for proper operation.



TECHNICAL SERVICE BULLETIN

PRODUCT SERVICE DEPARTMENT

TROY, OH. 45374-0001

D340 SERIES - REPLACEMENT G.E. MOTOR INFORMATION

Purpose

Current production Model D340 three phase mixers now use G.E. motors. The new G.E. motors are a direct bolt-in replacement for previous Hobart or Ramco motors. The GE motors are slightly longer than previous motors; therefore, the motor cover must also be changed when replacing a non - G.E. motor.

G.E. motors are also being used as the replacement motor for Model D340 single phase mixers w/o brake.

Serial Number Cutoffs

G.E. three phase motors are installed in D340 mixers built beginning with Serial No. 31-1240016 and higher.

Parts Information

Voltage Specifications	G.E. Motor Replacement
208/60/3	875334-1
240-480/60/3	875334-2
208/60/1	875334-3
120/240/60/1	875334-4

NOTE: Replacement motor parts to service Ramco single and three phase motors are still available.

ML-103221 and ML-104484 single and three phase motors with brake and motor service parts for these motors are also available as service parts.

Due to ventilation requirements on earlier Hobart and Ramco motors, the original motor cover must be used whenever using either of these motors. Ventilation requirements also apply to the new G.E. single phase motor, but due to the additional length of the motor, a new motor cover must be ordered and installed when installing a G.E. single phase motor assembly. The G.E. three phase motor does not require out of the machine ventilation, and a new motor cover has been designed to both seal the pedestal motor opening and provide the necessary clearance required when using the G.E. three phase motor.

Whenever a single or three phase motor assembly is ordered for D340 mixers (except motors with brake), a G.E. replacement motor will be sent.

When ordering a motor to replace a Hobart or Ramco motor, a new style motor cover must also be ordered and installed.

REPLACEMENT MOTOR COVER		
Motor Manufacturer		Motor Cover Part No.
Hobart or Ramco	Single Phase	274668
	Three Phase	271300-1
G.E.	Single Phase	479512
	Three Phase	875377

Reference Material

Parts Catalog No.	ML No.
F-17838 Rev. A (5/92)	ML-103221
	ML-103330
F-19154 Rev. A (7/01)	ML-104883
	ML104884

For service material information, refer to TSB 770 "D340 MIXER - INTRODUCTION", (1-90).

Installation Information

WARNING: DISCONNECT THE ELECTRICAL POWER TO THE MACHINE AT THE MAIN CIRCUIT BOX. PLACE A TAG ON THE CIRCUIT BOX INDICATING THE CIRCUIT IS BEING SERVICED.

NOTE: The G.E. motors do not have a tapped hole in which to secure the component mounting panel. The front mounting machine screw will not be needed. Follow the procedure to secure the front of the component mounting panel to the mixer. This procedure applies to both single and three phase motors.

NOTE: Mixers produced using a G.E. motor will not need the modification outlined in the procedure.

Securing Component Mounting Panel

1. Remove top cover assembly from mixer.

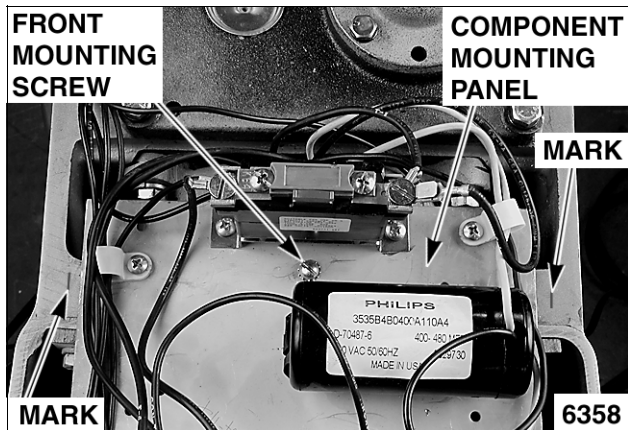

2. Remove motor cover and discard.
3. With component mounting panel secured to original motor, measure $3/16$ " from sides of component mounting panel and mark each side of transmission case.
4. Center punch both marks.
5. Remove component mounting panel.
 - A. Discard front mounting screw.
6. Remove motor.

NOTE: Refer to the appropriate service manual for motor removal and replacement procedure.

CAUTION: Drilling deeper than 0.480" could damage the pedestal to transmission case cap screw and/or threads.

7. Drill a No. 25 (0.1495") hole $0.450" \pm 0.030$ " deep in the two center punched locations made earlier.
8. Clean holes and machine of metal shavings.
9. Tap both holes with 10-24 tap (use bottom tap). Tap holes to a depth of $0.315" \pm 0.015$ ".

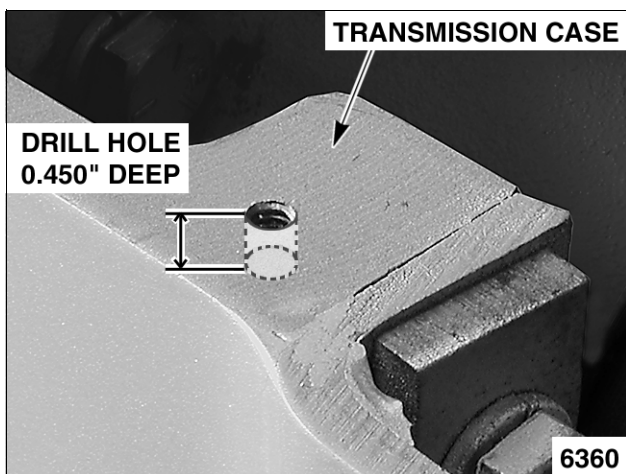

NOTE: The G.E. motor is a direct bolt-in replacement. Refer to the appropriate service manual when installing the new motor.

10. Perform motor replacement.
11. Position component mounting panel equally between holes.
12. Place a $1/4" \times 5/8" \times 1/16$ " washer Part No. WS 003-07 on 10-24 x $1/2$ " screw Part No. SC 018-02 and apply Loctite 222 to threads of screw before assembly.
13. Assemble screws and washers onto transmission case capturing component mounting panel under a portion of the washer.
14. Tighten screw until washer is just tight against component mounting panel then back off screw $1/2$ to $3/4$ turn.

NOTE: Approximately half of washer is to rest on top of component mounting panel.

14. Tighten screw until washer is just tight against component mounting panel then back off screw $1/2$ to $3/4$ turn.

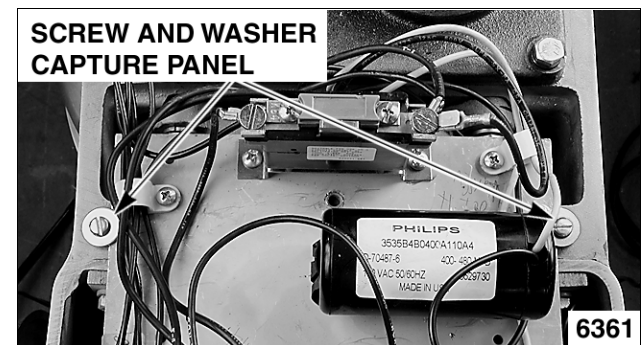

NOTE: Make certain that component mounting panel is free to move forward and backward without binding.

15. Install new motor cover.
16. Check for proper operation.
17. Reassemble top cover assembly.